

# Turbomat

TM 150/200/250

TM 300/320/400/500

**STURDY CONSTRUCTION  
INDUSTRIAL MODEL**



# High-tech without limits



From the very beginning Froling has specialised in the efficient use of wood as a source of energy. The name Froling stands for state-of-the-art biomass heating technology. Froling firewood, wood chip and pellet boilers are successfully in operation all over Europe. All of our products are manufactured in our factories in Austria and Germany. Our extensive service network guarantees full coverage and reliability.

## Wood chips, shavings, pellets and more



Wood chips are a local and environmentally-friendly fuel, which is not subject to the crises and fluctuations of the market. Furthermore, wood chip production provides jobs for local residents. That is why wood chip is the perfect fuel, not just from an economic perspective, but also from an environmental point of view. Scrap wood such as branches, twigs and sawmill cuttings are turned into wood chips with a cleaver. The quality class is determined by the wood used.



Wood pellets are made of natural wood. The large volumes of wood shavings and sawdust generated by the wood-processing industry are compacted and pelleted without being treated beforehand. Pellets have a high energy output and are easy to deliver and store. These are just some of the advantages that make pellets the perfect fuel for fully automatic heating systems. Pellets are delivered by tanker and unloaded directly into your store.

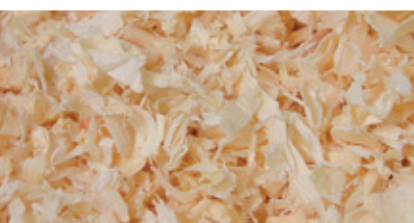

Shavings are a waste material and a by-product of the wood-processing industry, and are therefore logically the ideal fuel for this industry. The characteristics of this exceptional dry heating material require particularly robust combustion technology.

## Invest in the future

Froling's Turbomat is a unique heating system with a fully automatic wood burner which will operate with a wide variety of wooden material. As a leading manufacturer of biomass heating systems, the Turbomat embodies all of Froling's expertise in pioneering innovation. We were looking for a boiler that would be perfectly suited for burning other biomass fuels as well as wood chips.

The Turbomat not only boasts innovative combustion technology but also offers impressive control options. With Lambda controls as standard, combustion chamber temperature monitoring and under-pressure control, perfect combustion is guaranteed for a range of materials. The **comfort** provided sets new standards in this performance category.

All Turbomat functions are **fully automatic**, from fuel feed and combustion right through to cleaning and ash removal. The high-tech Turbomat is designed to be extremely **robust, durable and easy to service**.



# Sturdy technology with smart details

TURBOMAT 150/200/250



Suggested system

## Highlights:

- 1** Trapezoidal stoker duct guarantees minimal energy consumption in the feed area and full flexibility for varying fuel sizes. The industry standard drive gear unit is durable and mechanically isolated from the feed channel. This prevents the screw movements from affecting the gear unit. A bonus feature of the TM 220/250 is also the fact that the feed area is water-cooled in the high temperature range. This serves the very practical purpose of pre-drying the heating material where the fuel has a high moisture content.
- 2** 4-layer high temperature combustion chamber (firebrick / insulation 1 / air jacket / insulation 2) made of premium, heat-resistant fireclay components for optimal combustion, even with inferior fuel (e.g. high moisture level etc.) or alternative fuel, such as miscanthus.
- 3** Moving grate for constantly homogeneous combustion process with ongoing removal of combustion residue.
- 4** Automatic ash removal for transport into adjacent ash containers.
- 5** Vertical 3-pass heat exchanger and Efficiency Optimisation System (EOS) with automatically operated turbulators for cleaning and for minimal dust emissions (<50 mg/Nm<sup>3</sup>).
- 6** Flue gas recirculation FGR (optional) optimises burning (output, emissions etc.) with particularly demanding fuels, e.g. pellets, shavings, miscanthus etc.
- 7** Speed-regulated and function-monitored induced draught fan together with the under-pressure controller ensure that the system continuously adapts to changes in fuel and the chimney conditions.
- 8** Multilayer thermal insulation guarantees minimum radiant heat.
- 9** Large, solid combustion chamber doors ensure ease of access for maintenance.

# A design with unique benefits

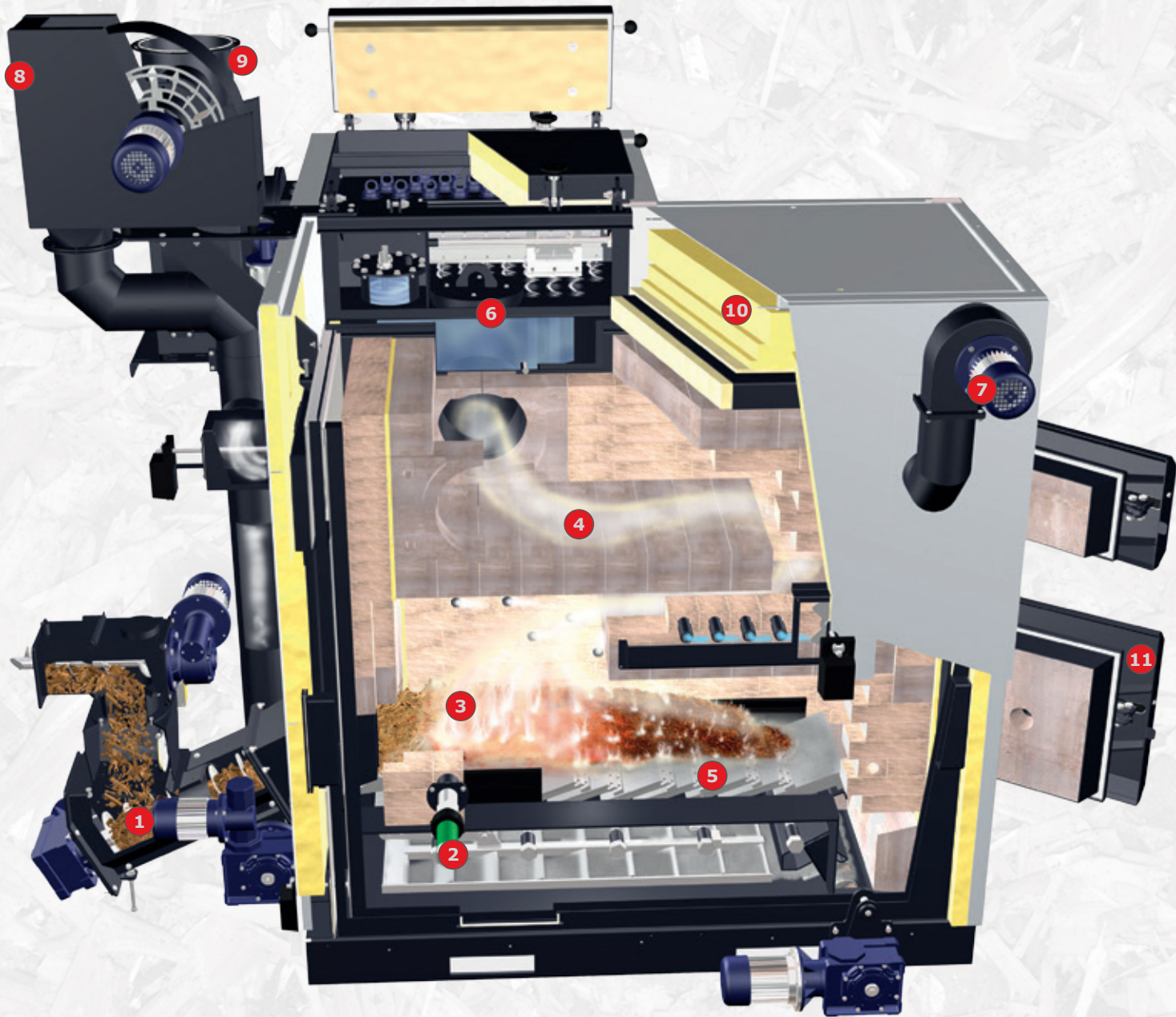

TURBOMAT 300/320/400/500

## Highlights:

- 1** Trapezoidal stoker duct guarantees minimal energy consumption in the feed area and full flexibility for varying fuel sizes. The industry standard drive gear unit is durable and mechanically isolated from the feed channel. This prevents the screw movements from affecting the gear unit. A bonus feature is also the fact that the feed area is water-cooled in the high temperature range. This serves the very practical purpose of pre-drying the heating material where the fuel has a high moisture content.
- 2** Second ignition fan (optional) for heating material that is hard to light (e.g. damp).
- 3** 4-layer high temperature combustion chamber (firebrick / insulation 1 / air jacket / insulation 2) made of premium, heat-resistant fireclay components for optimal combustion, even with inferior fuel (e.g. high moisture level etc.) or alternative fuel, such as miscanthus.
- 4** High-temperature post combustion zone with hot fireclay lining prolongs combustion. This increases efficiency even further, particularly with inferior fuels.
- 5** Moving grate for constantly homogeneous combustion process with ongoing removal of combustion residue. The innovative primary air zone separation system produces exceptional combustion results with CO emissions below 10 mg/MJ!
- 6** Vertical, patented 4-pass heat exchanger with integrated suction cyclone unit dust separation unit and Efficiency Optimisation System (EOS) with automatic cleaning function. Operating pressure up to 6 bar.
- 7** Case cooling of combustion chamber minimises radiant heat. The heat is specifically used to pre-heat the combustion air.
- 8** Flue gas recirculation FGR (optional) optimises burning (output, emissions etc.) with particularly demanding fuels, e.g. pellets, shavings, miscanthus etc.
- 9** Speed-regulated and function-monitored induced draught fan together with the under-pressure controller ensure that the system continuously adapts to changes in fuel and the chimney conditions.
- 10** Multilayer thermal insulation guarantees minimum radiant heat.
- 11** Large, solid combustion chamber doors ensure ease of access for maintenance.

# Well-planned in every detail

**Feature: high temperature combustion chamber with moving grate**

- Advantages:
- no cinder build-up
  - optimum burnout
  - very low emissions
  - automatic ash removal

The high-temperature combustion chamber is 4-shelled, guaranteeing clean combustion. The jacket cooling, together with the water-cooled stoker duct minimise radiant heat losses and guarantee high efficiency. Thanks to the moving conveyor grate, boiler operation is trouble- and maintenance-free, even when using low-grade fuels which tend to form cinder. Separation of the primary air zone guarantees full, efficient burnout. This keeps emission levels very low (CO less than 10 mg/MJ) The ashes that fall under the grate are automatically transported to the ash container by a rake.

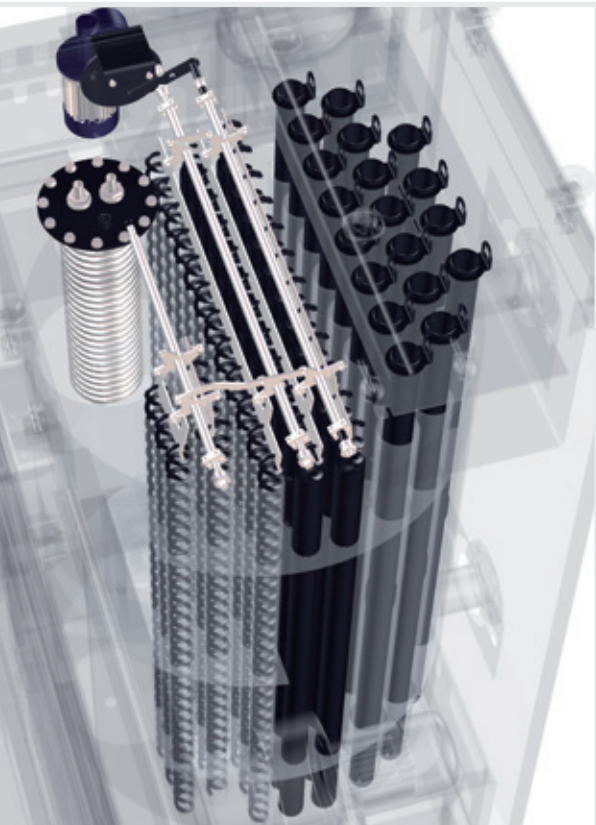
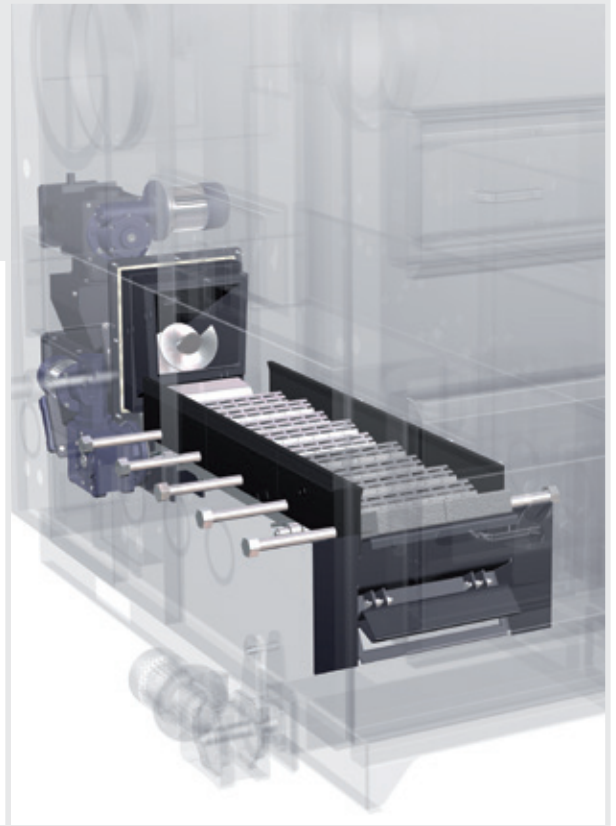

**Feature: upright heat exchanger**

- Advantages:
- optimal heat transfer
  - automatic cleaning of heating surfaces
  - high efficiency
  - very low dust emissions

The upright design means that the heat-exchanger practically cleans itself. The heating surfaces can also be cleaned automatically, which means high efficiency. The built-in safety battery prevents over-heating. The patented multi-cyclone dust separator integrated in the heat exchanger of the Turbomat 320 and 500 ensures compliance with the lowest dust emission limit values. Ash is removed by sturdy screws, which feed it into containers. These are outside the unit, so they are easy to remove and empty.



**Feature: service-friendly, sturdy design**

- Advantages:
- maintenance work kept to a minimum
  - components easy to service
  - cost savings
  - extremely high operating safety

The high-tech Turbomat is extremely easy to service. All components, from the fire bricks to the grate elements, are easy and inexpensive to replace if necessary. The built-in burn back flap or rotary valve, combined with the under-pressure monitoring system, ensures safe operation.

In the case of an emergency you can continue operation by connecting up an oil burner or a gas burner.

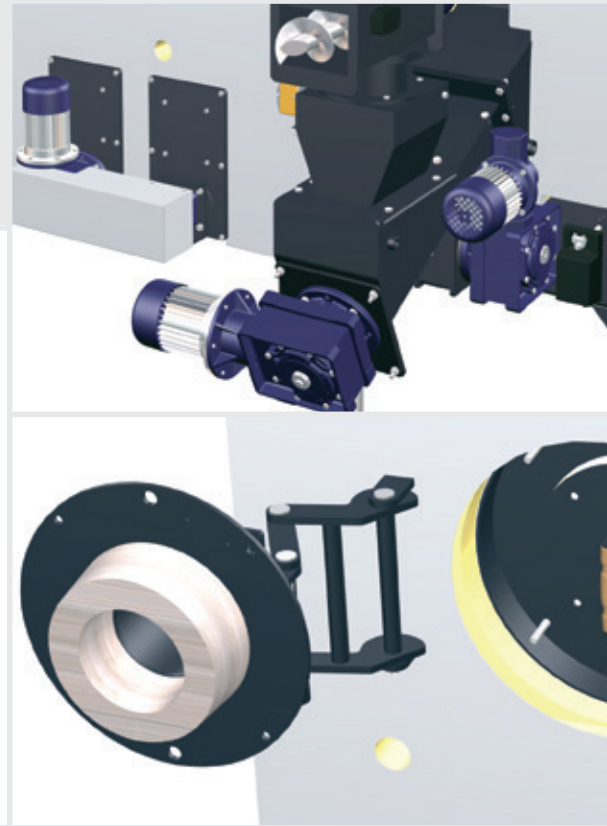

**Feature: flue gas recirculation**

- Advantages:
- combustion optimisation
  - preserves the flame-swept parts

Some of the flue gas is fed back into the combustion by a speed-regulated FGR blower fan. The residual oxygen in the flue gas is fed back to the combustion zone by automatic progressive rotary slide valves serving as the primary and secondary flue gas return. This reduces the NOx emissions. It also helps to protect the fireclay when high-quality dry fuels are used whilst optimising combustion and output for both damp and dry fuels.

# Technical specifications

## Turbomat 150/200/250

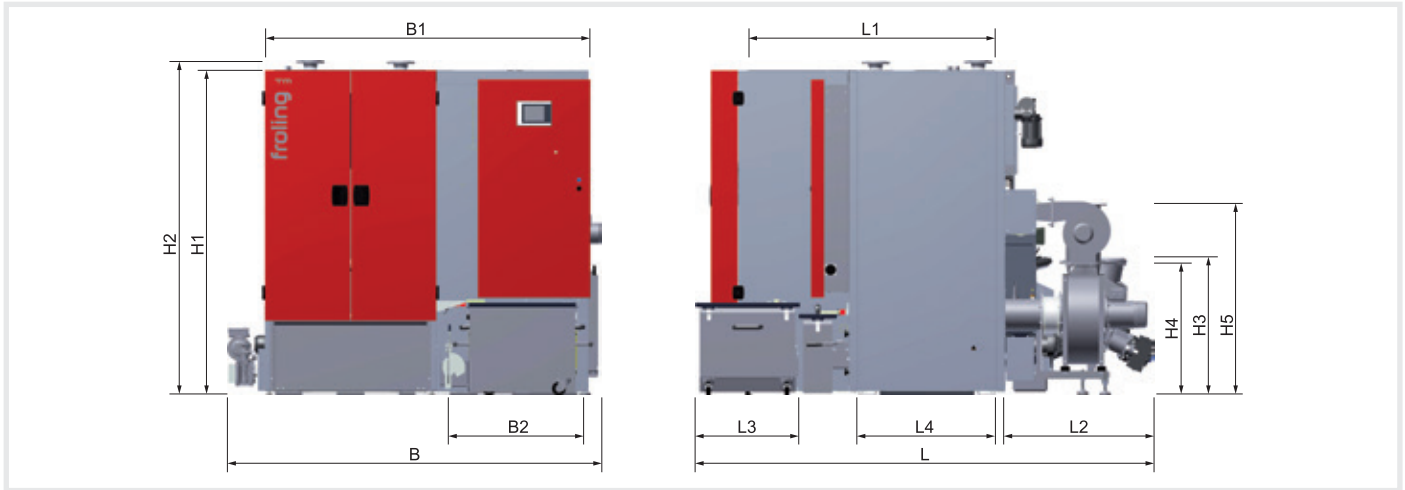

DIMENSIONS		TM 150	TM 200	TM 250
H1	Height, boiler incl. insulation [mm]	1880	1880	1880
H2	Height of flow connection / return connection (mm)	1935	1935	1935
H3	Height, stoker incl. burn back protection system [mm]	790	850	850
H4	Height of flue gas pipe connection without FGR [mm]	770	800	800
H5	Height of flue gas pipe connection incl. FGR [mm]	1105	1080	1080
B	Total width incl. fittings [mm]	2170	2180	2180
B1	Width, boiler incl. insulation [mm]	1870	1930	1930
B2	Width, ash trolley [mm]	870	870	870
L	Total length incl. fittings [mm]	2630	2860	2860
L1	Length, combustion chamber excl. insulation [mm]	1720	1880	1880
L2	Length of stoker unit [mm]	940	970	970
L3	Length of ash trolley [mm]	600	600	600
L4	Length, heat exchanger excluding insulation [mm]	790	950	950

TECHNICAL SPECIFICATIONS		TM 150	TM 200	TM 250
Nominal heat output (P45A - prev. W30 - woodchips as per ÖNORM)	[kW]	150	199	250
Total weight incl. fittings	[kg]	3300	3820	3820
Flue gas pipe diameter	[mm]	200	250	250
Water capacity	[l]	440	570	570
Maximum permitted operating temperature	[°C]	90	90	90
Minimum return temperature	[°C]	65	65	65
Max. permitted working over-pressure	[bar]	3	3	3
Flue gas temperature at nominal load	[°C]	150	150	150

## Turbomat 300/320/400/500

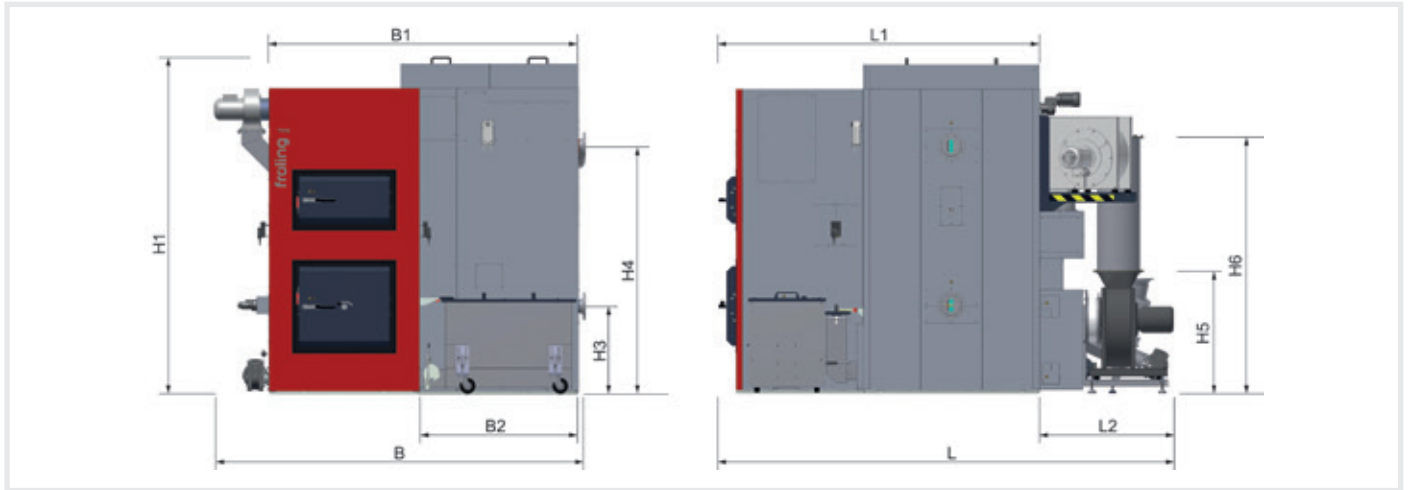

DIMENSIONS		TM 300/320	TM 400/500
H1	Total height [mm]	2560	2720
H3	Height of return connection (mm)	640	710
H4	Height of flow connection (mm)	1850	2000
H5	Height of flue gas pipe connection without FGR [mm]	960	985
H6	Height of flue gas pipe connection incl. FGR [mm]	1905	2075
B	Total width of the system [mm]	2780	2990
B1	Width of boiler [mm]	2200	2500
B2	Width of heat exchanger [mm]	1080	1280
L	Total length [mm]	3390	3660
L1	Length of boiler [mm]	2360	2600
L2	Length of stoker unit [mm]	1030	1060

TECHNICAL SPECIFICATIONS		TM 300	TM 320	TM 400	TM 500
Nominal heat output (P45A - prev. W30 - woodchips as per ÖNORM)	[kW]	300	320	400	500
Flue gas pipe diameter	[mm]	300	300	350	350
Diameter of stoker screw	[mm]	150	150	200	200
Total weight incl. fittings	[kg]	6200	6200	8400	8400
Water capacity	[l]	560	560	750	750
Maximum permitted operating temperature	[°C]	90	90	90	90
Minimum return temperature	[°C]	65	65	65	65
Maximum permitted operating pressure	[bar]	6	6	6	6
Flue gas temperature at nominal load	[°C]	140	140	140	140

# Fueling feeder system

## Froling discharge systems - design development perfected over decades

Froling has expertise designing discharge systems spanning many years. Whether the system is large or small, Froling provides sturdy feeder systems, which meet the highest technical standards. For example, you can connect a hydraulic loading system ideal for bulky or bundles fuels to the Turbomat 320 or Turbomat 500.

### Torsion arm agitator (TGR)



For discharging fuels from bunkers with a maximum working diameter of 6.0metres. The system is low maintenance and is especially designed for fuels with greater discharge power due to their limited ability to trickle. The patented design guarantees quiet and effective operation.

### Inclined screw discharge unit



Mainly used as a silo discharge screw in the wood-processing industry. Ensures even and reliable fuel feed from high silos.

## Horizontal screw discharge unit



Solid construction to withstand extremely high feed loads when feeding from high silos. This is used for shavings and for large-diameter bunkers in particular.

## Pusher discharge unit

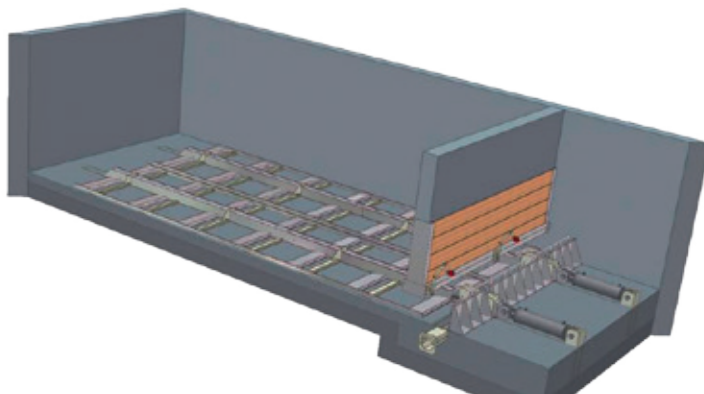

Optional design for rectangular storage rooms. Suitable for all commonly-used biomass fuels. The pusher discharge unit is extremely sturdy and has proven to be especially suitable for discharging fuels from large wood chip stores.

Furthermore, there are numerous flexible solutions available for individual fuel transport such as scraper chain conveyors, conveyor belts, vertical transport systems, feeder systems without screws, fully hydraulic loading systems, etc.

**Please contact our sales engineers for further details.**

# Systematic convenience

## Feature: **Lambdatronic H 3000 control**

- Advantages:
- optimum combustion control
  - adjusts to different fuel characteristics
  - remote maintenance (optional)

The Lambdatronic modular control concept ensures ideal combustion. The boiler automatically adjusts to the various characteristics of the fuels being used. Furthermore, the Lambdatronic control system provides weather-compensated control of the heating circuits and precise control of the storage systems. Using a modem, maintenance can be carried out directly by Froling through a remote system. The Lambda control system with precision primary, secondary and tertiary air control, the combustion chamber temperature monitoring system, the under-pressure control system (which monitors the intensity of the bed of embers) and the flue gas recirculation system all ensure optimum combustion.



## Feature: **NEW: Froling SPS 4000 controller**

- Advantages:
- powerful SPS controller with 5.7" colour touch display
  - safe and simple remote access via Froling visualisation software
  - numerous functional possibilities

The new SPS 4000, made of industry-standard high-quality components, is now available as an option. The clear, user-friendly control system offers a wide range of different settings and display options for individual, efficient and stable operation. The Froling SPS 4000 offers numerous functional possibilities such as 5 sensor storage tank management, heating circuit and network temperature control, external power specifications, cascade function, integration, monitoring and controlling of additional peripheral components. Froling visualisation software offers transparency thanks to its trend, status and alarm recording features.

## Feature: **Froling Visualisation Software**

- Advantages:
- monitor and operate from your PC
  - record boiler data
  - remote control via modem

structure make it easy to use. In combination with a modem, it is possible to connect to the visualisation software via the telephone network. This means that the heating system can be monitored from any location.

The optional boiler display software enables convenient remote control of the system from a computer. All operating values and parameters can be displayed and modified. The Windows interface and clear menu

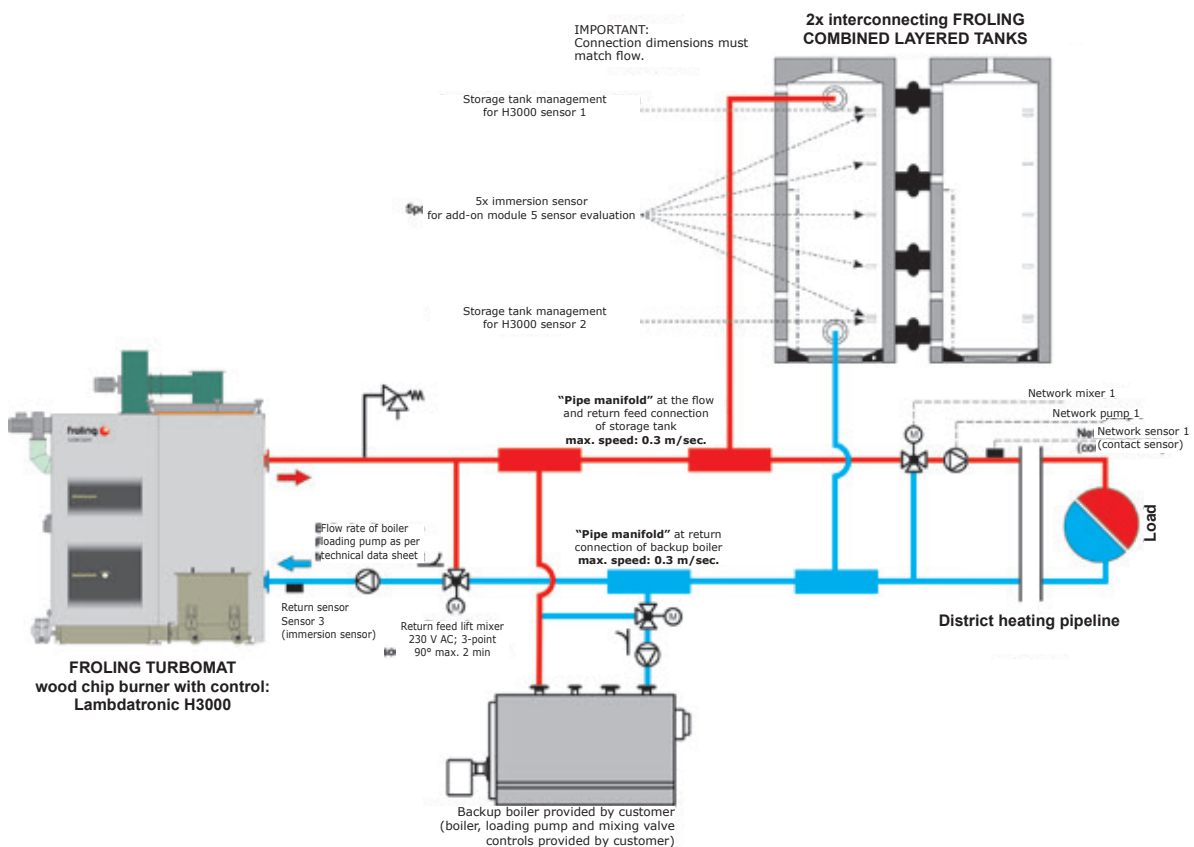
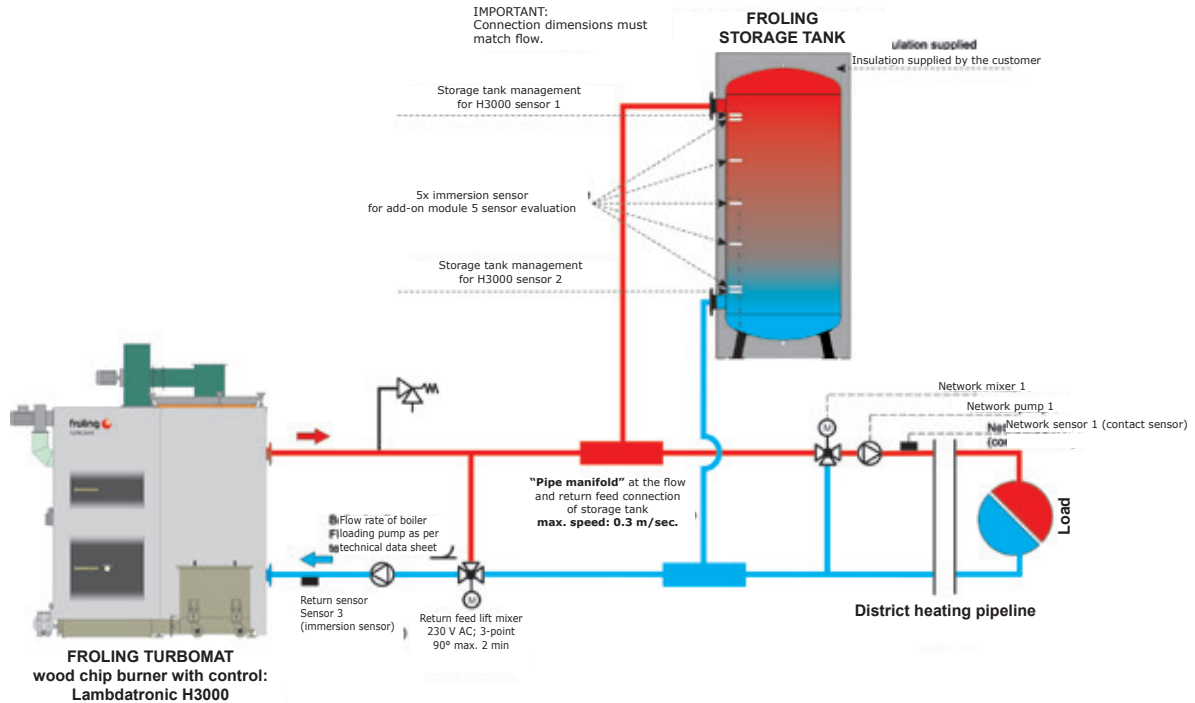

# Bunker filling system

## BFSV / BFSU / BFSV-H bunker filling system

- Advantages:
- Easy to assemble
  - High feed output (up to 45 m<sup>3</sup>/h)
  - Great ejection distance (up to 9 m)
  - Optimum fuel distribution
  - Suitable for P16A - P45A wood chips (previously G30 / G50)

Froling bunker filling systems, both vertical (**with vertical feed screw BFSV**) and horizontal (**with horizontal feed screw BFSU**) set new standards for feed output (up to 45 m<sup>3</sup>/h), operating safety and bunker filling.

A screw transports the wood chips from the tipping gutter into the vertical feed system, which transports the fuel to the desired height for the centrifugal disc. In this way, the Froling bunker filling systems fill the store space without producing much dust and ensure the best possible distribution of the fuel in the bunker.

### High feed output and maximum ejection distance

The separate drive for the high speed centrifugal disc enables a particularly good ejection distance. However, the ejection distance depends on the grain size and the weight of the fuel and the position of the centrifugal disc. The coarser and heavier the wood chips and the higher the position of the ejection head, the greater the trajectory. Depending on the fuel characteristics and local conditions, ejection distances of up to 9 metres can be achieved.

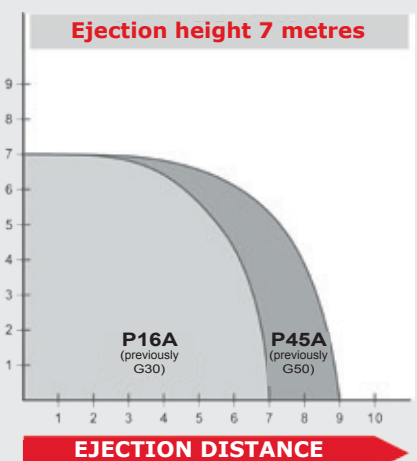
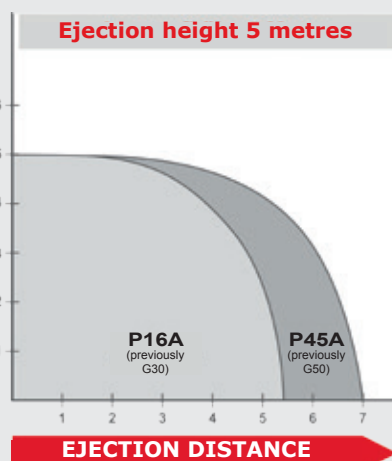
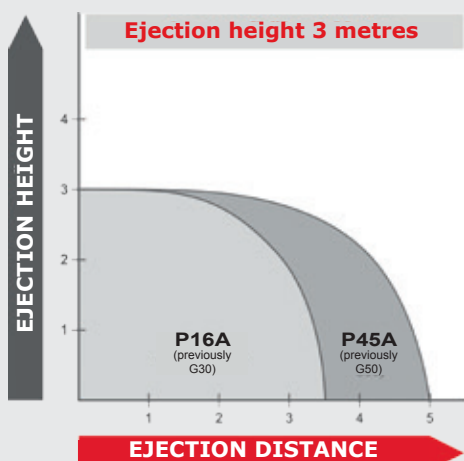
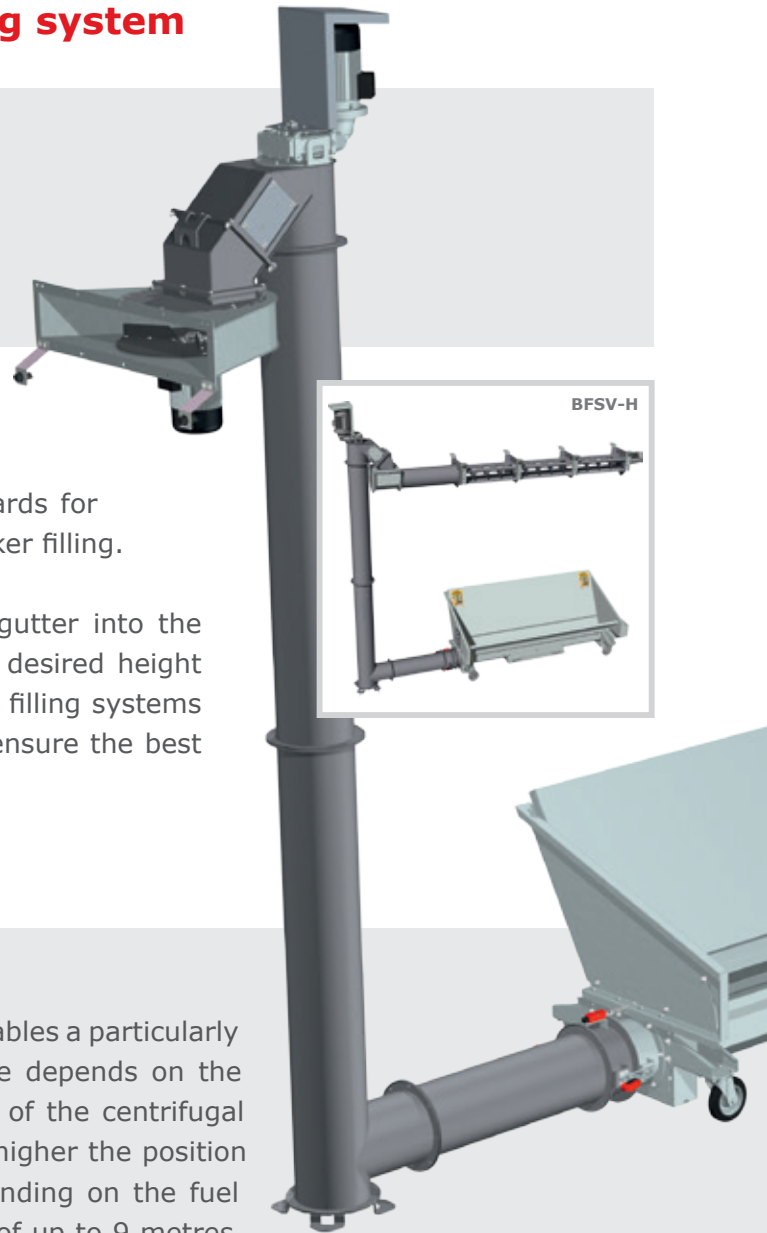



# BFSV / BFSU / BFSV-H



## Feed screw

The coreless feed screw ( $\varnothing$  225 mm) guarantees long service life and smooth operation, even with coarse wood chips.



## Fill level recognition

Two sensors recognize when the store space is full and automatically stop the fuel feed.

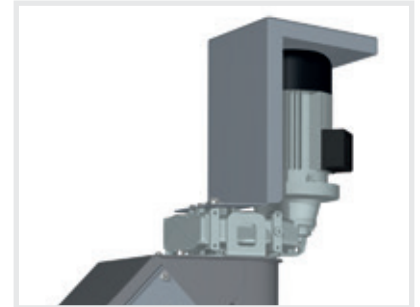

## Energy saving drives

All of the drives have an efficiency rate of over 90% and ensure low energy operation. All of the drives in the store space feature explosion protection.

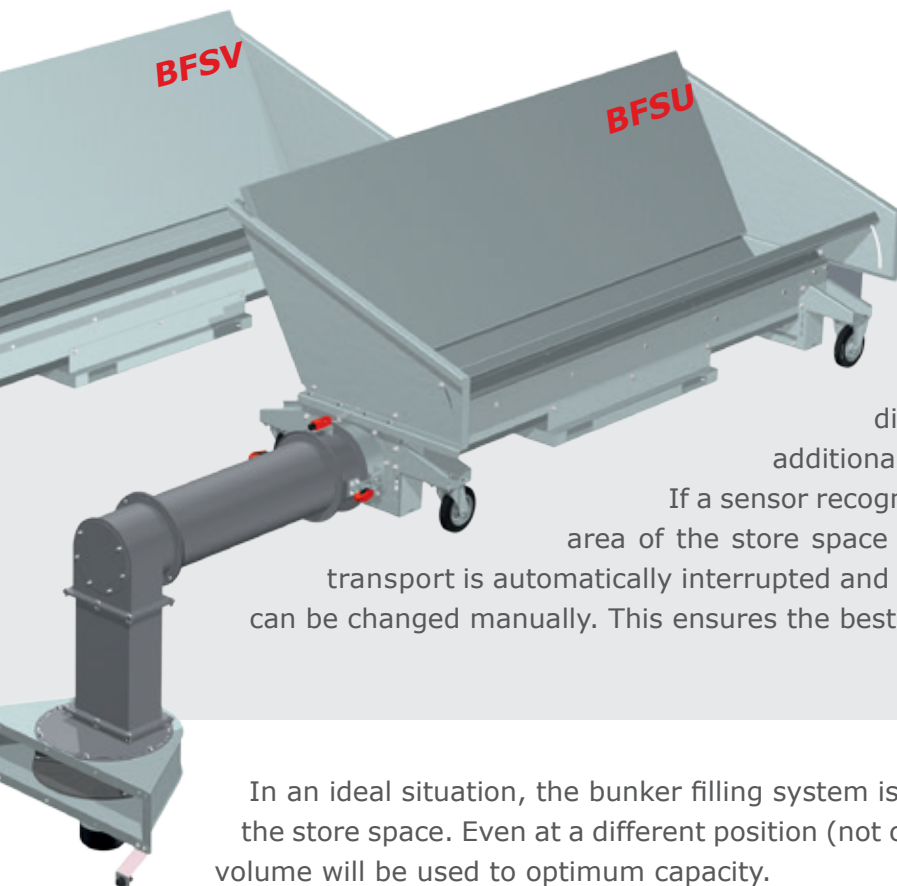

## Optimum fuel distribution

The right/left-hand motion of the centrifugal disc ensures a good filling level in the bunker. An additional plus is the **semi-automatic turn control**.

If a sensor recognizes the fill level indication that the fuel in this area of the store space has reached the maximum fill level, the fuel transport is automatically interrupted and the direction of rotation of the centrifugal disc can be changed manually. This ensures the best possible fuel distribution in the bunker.

In an ideal situation, the bunker filling system is positioned in the centre at the narrow end of the store space. Even at a different position (not centred, at the wide end, etc.), the store space volume will be used to optimum capacity.

BFSV / BFSU

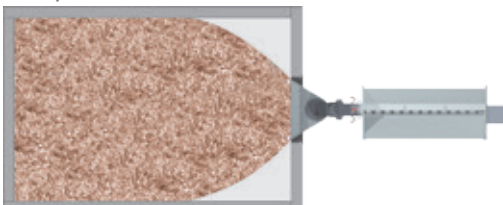

BFSV / BFSU

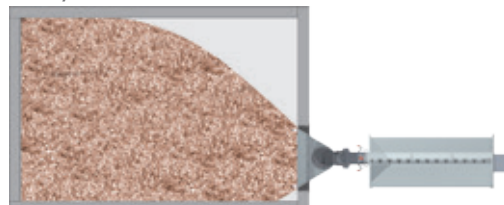

BFSV



# Energy box

## Froling Energy box

Heating containers make it possible to locate the boiler and fuel storage room wherever you wish. This saves space and enables installation of biomass heating, especially when renovating an existing building.

The Froling energy box is available in two versions (Modular and Individual) and is the ideal container solution for heating with wood chips, pellets and shavings. While the Modular version (made from reinforced concrete) is a standardised design offering excellent value for money, the Individual version (made from either reinforced concrete or steel) offers solutions for almost any requirement.



# Individual energy box

## Froling energy box

The Individual energy box is tailored specifically to your requirements, and the possibilities are virtually endless. Thanks to these wide-ranging options and personalised planning, the Individual energy box is ideal for the Froling TX, Turbomat and LAMBAMAT.

Planning by FROLING engineers ensures that the solution is just as complete as the Modular version. Heating system, feed system, fuel store or - depending on the model - storage tank and bunker filling system all come from the one supplier and are perfectly coordinated. For the finished container, you can choose between either reinforced concrete or steel.

### Output up to 500 kW

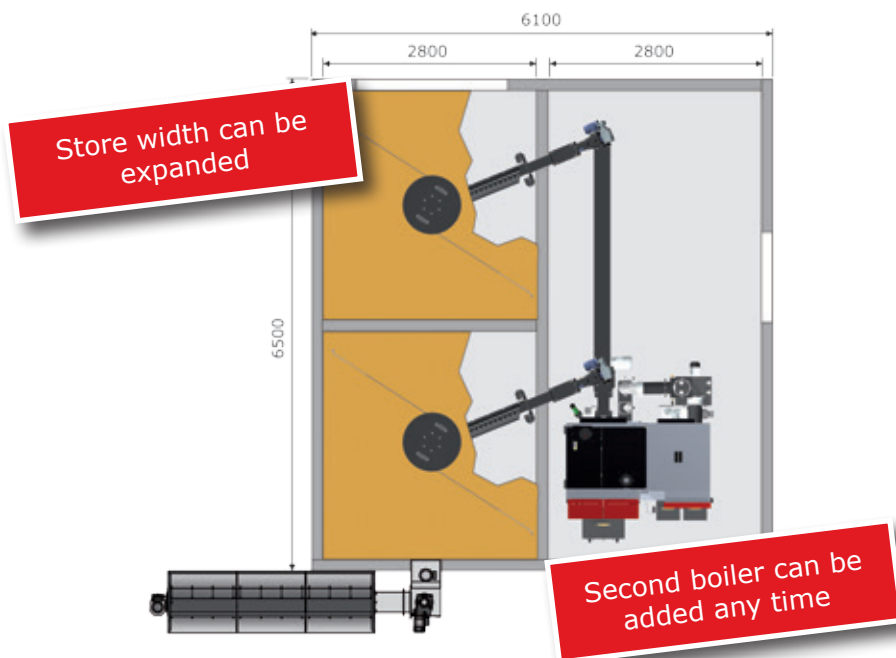

Individual energy box with two Turbomats and two FBR spring blade agitators and feed screw.

The second Turbomat wood chip system can be added any time, in which case the interim feed screw is no longer required.

The store space is filled directly via the large store space door using the vertical feed screw.

### Output up to 1000 kW



Froling Individual energy box with Turbomat 320 kW and Turbomat 500 kW. FBR spring blade agitator and articulated arm discharge unit for wood chip and pellet fuels.

The pellets are blown into the store space via filling pipe; wood chips are fed into the large store door.

# In operation across Europe



## ENGLAND - Ampleforth College

Boiler: Turbomat 320 kW  
Discharge: articulated arm feed unit / diameter 4 metres  
Fuel: wood chips



## SWEDEN - Tre Sagar

Boiler: Turbomat 220 kW  
Discharge: articulated arm feed unit / diameter 5.7 metres  
Fuel: wood chips



## GERMANY - Schloss Gaußig

Boiler: Turbomat 220 kW  
Discharge: hydraulic pusher feed unit with transverse conveyor unit  
Fuel: wood chips



## SPAIN - Cantabria

Boiler: 2 x Turbomat 150 kW - double boiler system  
Discharge: articulated arm feed unit / diameter 5 metres  
Fuel: wood chips

Further technical details upon request.  
Always at your disposal to advise you.



**Heizkessel- und Behälterbau GesmbH  
A-4710 Grieskirchen, Industriestr. 12**

AUT: Tel. +43 (0) 7248 606 • Fax +43 (0) 7248 606-600  
GER: Tel. +49 (0) 89 927 926-0 • Fax +49 (0) 89 927 926-219  
E-mail: [info@froeling.com](mailto:info@froeling.com) • Internet: [www.froeling.com](http://www.froeling.com)