



# S3 Turbo

AVAILABLE WITH  
BROADBAND LAMBDA PROBE  
AND SERVO-MOTORS



**5** YEAR  
WARRANTY  
subject to WARRANTY CONDITIONS

# From a renowned company



For more than 50 years Froling has specialised in the efficient use of wood as a source of energy. Today the name Froling stands for modern biomass heating technology. Froling firewood, wood chip and pellet boilers are successfully in operation all over Europe. All of our products are manufactured in our factories in Austria and Germany. Our extensive service network guarantees full coverage and reliability.

## **S3 Turbo: Top-quality boiler technology at a mid-range price**

The S3 Turbo firewood boiler focuses on the basics. It includes many features that you would normally only find in high-end firewood boilers.

- Patented, cylindrical high-temperature turbulence combustion chamber for excellent combustion values.
- Separate pre-heating chamber door for easy pre-heating.
- Carbonisation gas extraction system for smoke-free reloading.
- Speed-regulated induced draught fan for output control and full operating safety.



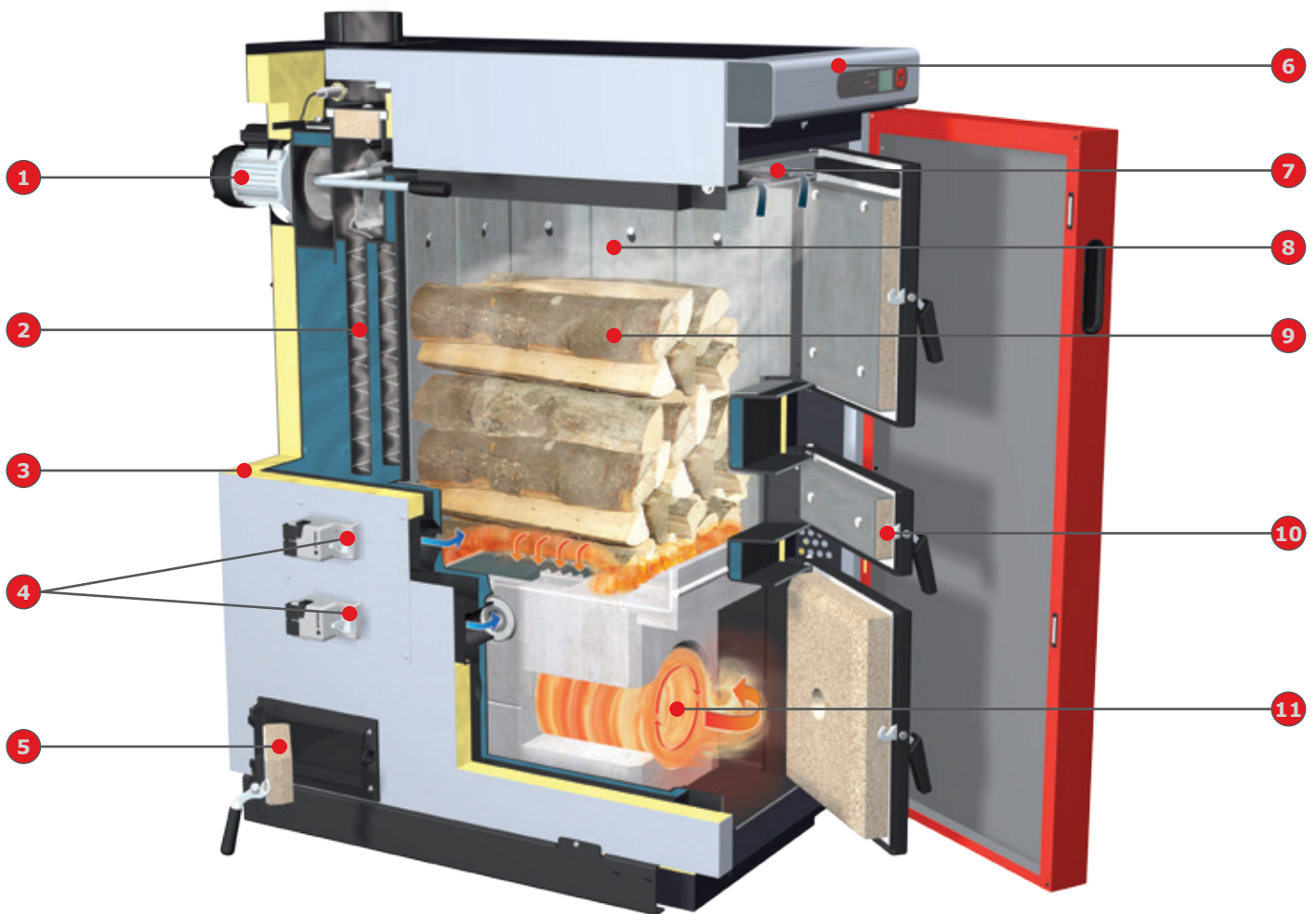

## The firewood boiler with special benefits:

- 1 Speed-regulated induced draught fan for maximum ease of use.
- 2 WOS (efficiency optimisation system) for high efficiency and easy cleaning.
- 3 Top quality thermal insulation.
- 4 Manual adjusters (or actuators with Lambdatronic) for primary and secondary air.
- 5 Large maintenance openings for easy cleaning.
- 6 S-Tronic controller or Lambdatronic controller
- 7 Carbonisation gas extraction system prevents flue gas from escaping during reloading.
- 8 Aprons (hot cladding) to protect the inner wall of the boiler for a longer service life.
- 9 Large fuel loading chamber for half-metre logs ensures long reloading intervals.
- 10 Separate pre-heating chamber door for easy pre-heating.
- 11 Patented high-temperature turbulence combustion chamber ensures low emissions.

# A successful design



**Feature: Large fuel loading chamber for half-metre logs**

- Advantages:
- Easy front-loading
  - Long combustion time
  - Long reloading intervals

The S3 Turbo can be loaded with half-metre firewood easily from the front. The loading chamber is 55 cm deep and has a generous reserve of space. Often it is only necessary to fill the boiler once a day. Strong steel guards protect the loading chamber and keep it clean.

**Feature: High-temperature turbulence combustion chamber**

- Advantages:
- Excellent combustion values
  - Low emissions
  - Much more environmentally friendly

Froling uses the patented, cylindrical high-temperature turbulence combustion chamber in the S3 Turbo. This means the boiler delivers excellent combustion values. The generous dimensions of the combustion zone guarantee low emissions. So by using a Froling S3 Turbo you are helping to keeping our air clean.

**Feature: WOS system**

- Advantages:
- Even greater efficiency
  - Easy cleaning from outside
  - Fuel savings

The WOS (efficiency optimisation system) consists of special turbulators, which are placed in the heat exchanger pipes. The lever arm mechanism ensures easy cleaning of the heating surfaces from outside. An additional benefit: clean heating surfaces lower energy consumption.

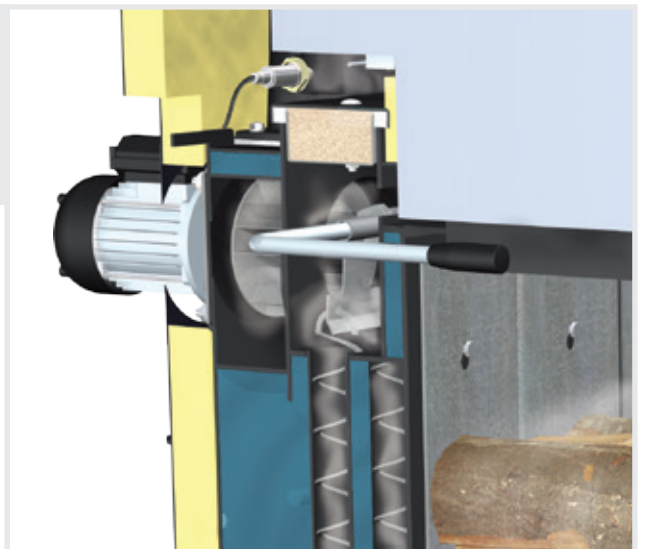



**Feature: Special carbonisation gas extraction system**

- Advantages:
- No flue gas escapes during reloading
  - The boiler room stays clean

The special carbonisation gas extraction system also prevents any gas from escaping when refilling. This is applicable at every stage of combustion. Enjoy modern heating with wood!

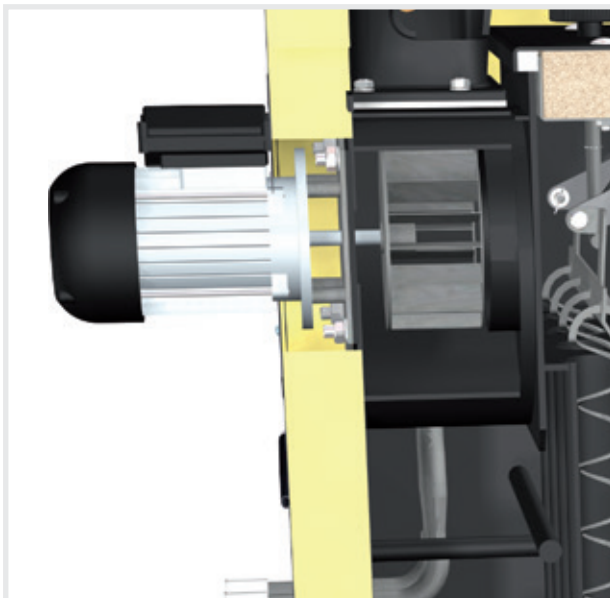

**Feature: Speed-regulated induced draught fan**

- Advantages:
- Easy to operate
  - Adapts to all operating conditions
  - Full operating safety

The primary and secondary air settings are adjusted by the technician during commissioning. The function-monitored induced draught fan enables the system to adjust to different operating conditions. This offers excellent output adjustment with full operating safety. In the S3 Turbo with broadband lambda probe the primary and secondary air settings are adjusted by means of servo-motors, ensuring that output is adapted to given requirements at every stage of combustion.

# Systematic convenience



**Feature: S-Tronic control**

- Advantages:
- Speed regulation and function monitoring of the induced draught fan for output adjustment
  - Integrated storage tank management
  - Alternating display of boiler, flue gas and storage tank temperatures



**Feature: S-Tronic plus control**

- Advantages:
- Speed regulation and function monitoring of the induced draught fan for output adjustment
  - Integrated storage tank management
  - Visual display with control keys for setting
  - Can be used to control 2 mixed heating circuits
  - Integrated boiler management



**Feature: Lambdatronic control**

- Advantages:
- Speed regulation and function monitoring of the induced draught fan for output adjustment
  - Lambda control with broadband lambda probe
  - Control of primary and secondary air via 2 servomotors
  - Integrated storage tank management
  - Visual display with control keys for setting
  - Can be used to control 2 mixed heating circuits
  - Integrated boiler management

## Option: Froling FRA room temperature sensor / RBG 3200/RGB 3200 Touch room console

The main modes of the designated heating circuit can be easily adjusted and selected using the Froling **FRA room temperature sensor**. The adjusting wheel allows you to change the room temperature by up to  $\pm 3^{\circ}\text{C}$ .

The **RBG 3200/RGB 3200 Touch room console** makes the system even easier to use. You can control the heating system easily from your living room. The important system data is clearly displayed and changes can be set at the push of a button.



The **Lambdatronic controller** controls the induced draught fan and offers the option of connecting a storage tank loading pump and a heating pump. Flue gas and boiler temperature monitoring ensures efficient combustion.

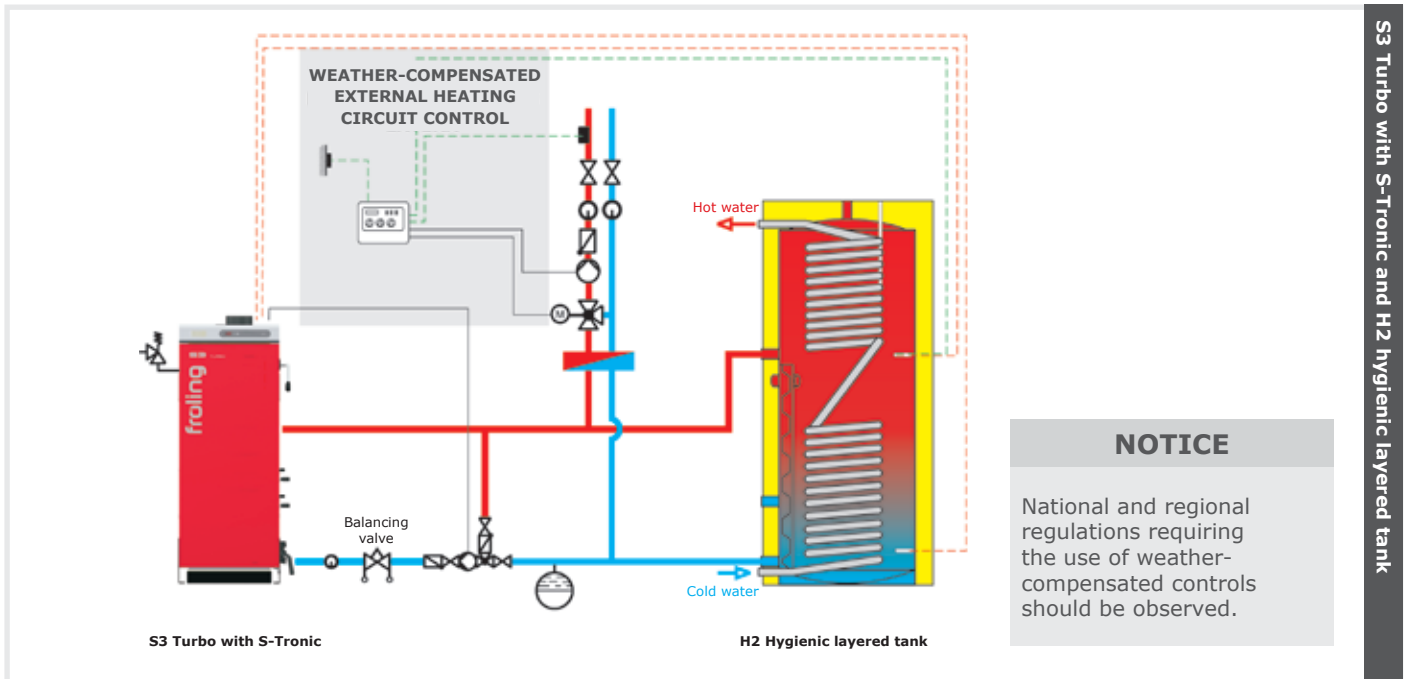

S3 Turbo with S-Tronic and H2 hygienic layered tank

The **Lambdatronic controllers** allow for efficient energy management. Up to 4 storage tanks, up to 8 hot water tanks and up to 18 heating circuits can be integrated into the heating management system. You also benefit from the ability to integrate other means of energy production, such as solar panels.

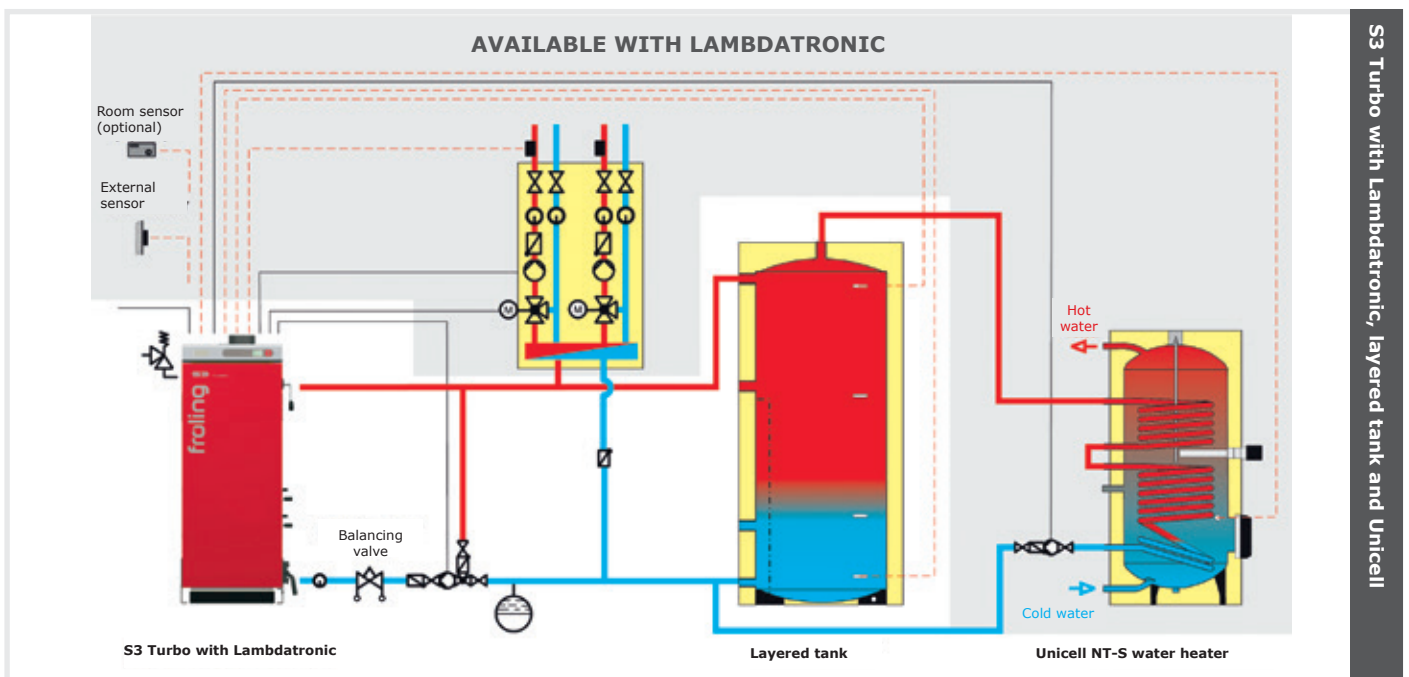

S3 Turbo with Lambdatronic, layered tank and Unicell

# Technical specifications

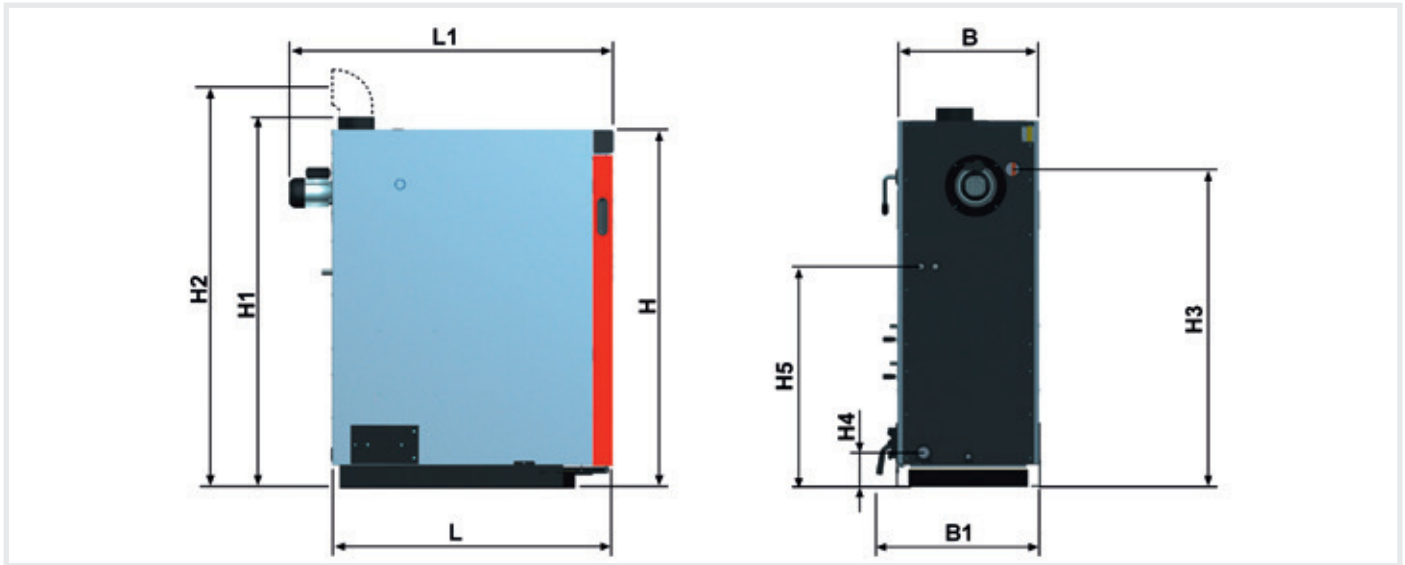

Dimensions - S3 Turbo		18	28	36	45	
L	Length of boiler	[mm]	1160	1160	1250	1250
L1	Total length including induced draught fan	[mm]	1260	1260	1350	1350
B	Width of boiler	[mm]	570	570	670	670
B1	Total width including side cleaning door	[mm]	680	680	780	780
H	Height of boiler	[mm]	1470	1470	1570	1570
H1	Total height including flue gas pipe	[mm]	1530	1530	1630	1630
H2	Height of flue pipe connection	[mm]	1750	1750	1850	1850
H3	Flow connection	[mm]	1280	1280	1380	1380
H4	Return connection	[mm]	140	140	140	140
H5	Safety heat exchanger connection	[mm]	890	890	970	970
	Flue pipe diameter	[mm]	150	150	150	150

Technical specifications - S3 Turbo		18	28	36	45
Nominal output	[kW]	22.5	31.0	36.0	45.0
Fuel loading chamber capacity	[l]	140	140	210	210
Fuel loading door (width/height)	[mm]	330 / 370	330 / 370	330 / 370	330 / 370
Water capacity	[l]	120	120	190	190
Boiler weight	[kg]	530	535	610	620

Your Froling partner:



**Heizkessel- und Behälterbau GesmbH**  
**A-4710 Grieskirchen, Industriestr. 12**  
 AUT: Tel. +43 (0) 7248 606 • Fax +43 (0) 7248 606-600  
 GER: Tel. +49(0)89927926-0 • Fax +49(0)89927926-219  
 Email: info@froeling.com • Internet: www.froeling.com

P0310413 - All illustrations intended as a guide only.  
 We reserve the right to make technical changes without prior notice. Errors and omissions excepted.  
 Source for third party images: www.aboutpixel.de