

PT4e

PELLET BOILER



BETTER HEATING

INNOVATIVE AND
CONVENIENT

froling 



ENVIRONMENTALLY
RESPONSIBLE
HEATING,
ECONOMICALLY
REWARDING



The price changes for different energy sources in recent years show the benefits of wood pellets: the environmentally clean way of heating is also economically attractive. Wood is a renewable energy source that is also CO₂-neutral. Pellets are made of natural wood. The large quantity of wood shavings and sawdust produced by the industry

are compacted and pelleted without being treated beforehand. Pellets have a high energy output and are easy to deliver and store. These are just some of the advantages that make pellets the perfect fuel for fully automatic heating systems. Pellets are delivered by tanker and unloaded directly into your store.

Froling has been working on the efficient use of wood as a source of energy for almost sixty years. Today the name Froling stands for modern biomass heating technology. Our firewood, wood chip and pellet boilers are successfully in operation all over Europe. All of our products are manufactured in our factories in Austria and Germany. Froling's extensive service network ensures that we can handle all enquiries quickly.

GUARANTEED
QUALITY AND
RELIABILITY
FROM AUSTRIA

- International pioneer in technology and design
- Sophisticated fully automatic operation
- Excellent environmental compatibility
- Environmentally responsible energy efficiency
- Renewable and CO₂-neutral fuel
- Ideal for all types of house
- More convenience and reliability
- Up to 5 year Froling-warranty (subject to warranty conditions)

Sturdy, convenient, reliable and versatile:
The new PT4e pellet boiler is perfect in every way.

Well-planned use of energy-saving drives ensures extremely low energy consumption. With its durable high temperature silicon carbide combustion chamber, the PT4e ensures a high level of efficiency with minimal emissions. In addition, the PT4e can be equipped with an electrostatic particle separator as an option.

Thanks to its modular construction, Froling's PT4e is particularly easy to position and install. The entire boiler comes fully assembled, electrically wired and tested.



PELLET BOILER PT4e

FOR EVEN MORE CONVENIENCE

7" touch display with LED status indication
for simple and intuitive operation

NEW!

Pellet boiler can be
retrofitted with integrated
particle separator
(electrostatic precipitator)
at any time

Large ash container
for long emptying intervals

NEW!

7" touch display with
LED status illumination





Multi-part combustion grate consisting of a fixed insertion zone and 2-part automatic tipping grate

Large pellet container

Two multi-chamber rotary valves

Geared motor for stoker screw

A WELL-DESIGNED HOME FOR GREATER CONVENIENCE

Easy to assemble on site

The PT4e is supplied assembled and wired. You just need to fit the stoker unit and connect the chosen discharge system to the supply bin. This saves time and money. Thanks to the well-planned layout of the units and its compact design, the PT4e can also be used in very confined spaces.

- Advantages:
- Quick installation
 - Pre-wired
 - Return temperature control already integrated (ex works)



Speed regulated EC induced draught fan

The speed-regulated EC induced draught fan ensures the exact air quantity for combustion. As the induced draught fan is speed-regulated, it stabilises combustion throughout and adjusts the air quantity to the output and the respective material. Working together with the lambda control, it ensures optimum combustion conditions. The EC induced draught fan has a significantly higher efficiency than conventional induced draught fans with AC motors. This results in significant power savings, especially in partial load conditions.

- Advantages:
- Maximum ease of use
 - Continuous optimisation of combustion
 - Up to 40% less power consumption



Precise primary and secondary air control

Combustion in the PT4e is controlled by underpressure. Combined with the EC induced draught fan, this guarantees extremely high operating safety. The innovative control of air distribution in the combustion zone is a new feature. Primary and secondary air are optimally adjusted to the conditions in the combustion chamber with only one actuator. This, combined with the lambda controller which comes as standard, ensures that emissions are kept to a minimum.

Fast, energy-saving ignition

The silent ceramic igniter ensures safe and energy-saving ignition of the fuel. Thanks to the hot combustion zone, after short periods in idle mode the fuel is automatically reignited by the residual embers. It is only necessary to start the igniter after longer combustion pauses.

- Advantages:
- Silent ceramic igniter for reliable ignition
 - Automatic combustion of residual embers
 - No separate blower fan required

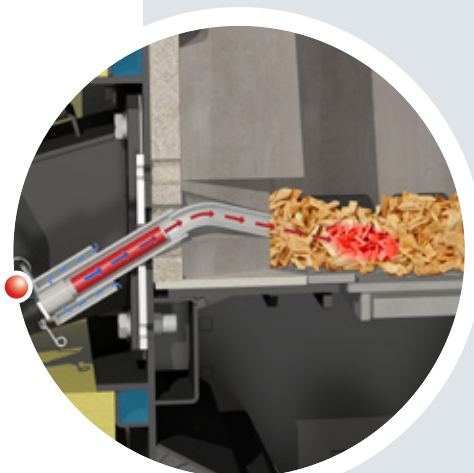

Cleaning of all heat exchanger pipes



Heat exchanger with automatic cleaning (WOS) of all passes and lower drive

The WOS (Efficiency Optimisation System) consists of special turbulators, which are placed in the heat exchanger pipes **(NEW! Now from first pass)** and allow automatic cleaning of the heating surfaces. Clean heating surfaces ensure greater efficiency and thus fuel savings.

- Advantages:
- Greater efficiency
 - Fuel economy
 - Drive mechanism in cold zone (low thermal load)

Permanently integrated return temperature control

The room temperature control integrated as standard avoids unnecessary radiant heat loss; this special feature guarantees maximum efficiency. An external return temperature control is therefore no longer necessary and saves installation time. The components are intelligently built-in and the main parts (e.g. pump) are visible from the outside and easily accessible.

- Advantages:
- Minimum radiant heat loss
 - Maximum efficiency
 - No external return temperature control required
 - Saves space in the boiler room

Line regulating valve (optional)

- Advantages:
- Can be retrofitted at any time
 - Optimum hydraulic balancing of the heating system

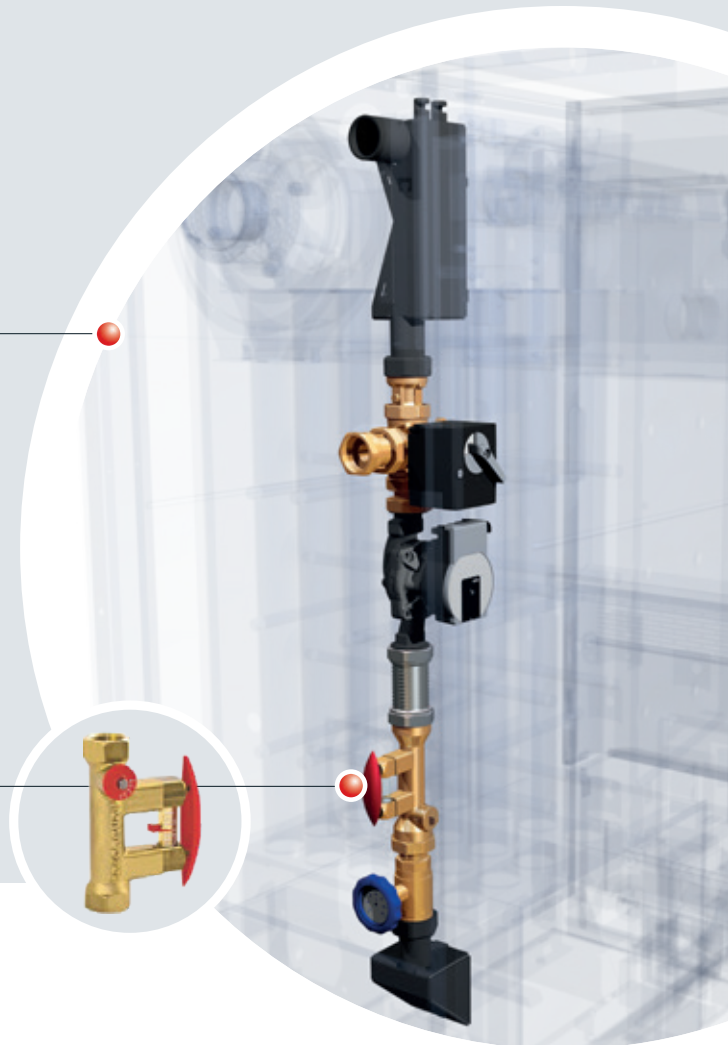

INTELLIGENT DESIGN IN EVERY DETAIL

Flue gas recirculation (FGR)

The flue gas recirculation system (FGR) mixes part of the flue gas with the combustion air and returns it to the combustion zone.

The FGR optimises combustion and performance, and also reduces NO_x emissions. The lower combustion temperatures offer added protection for flame-swept parts.

- Advantages:
- Precise adjustment via air actuators
 - Ideal combustion conditions
 - Intelligent control of air quantity

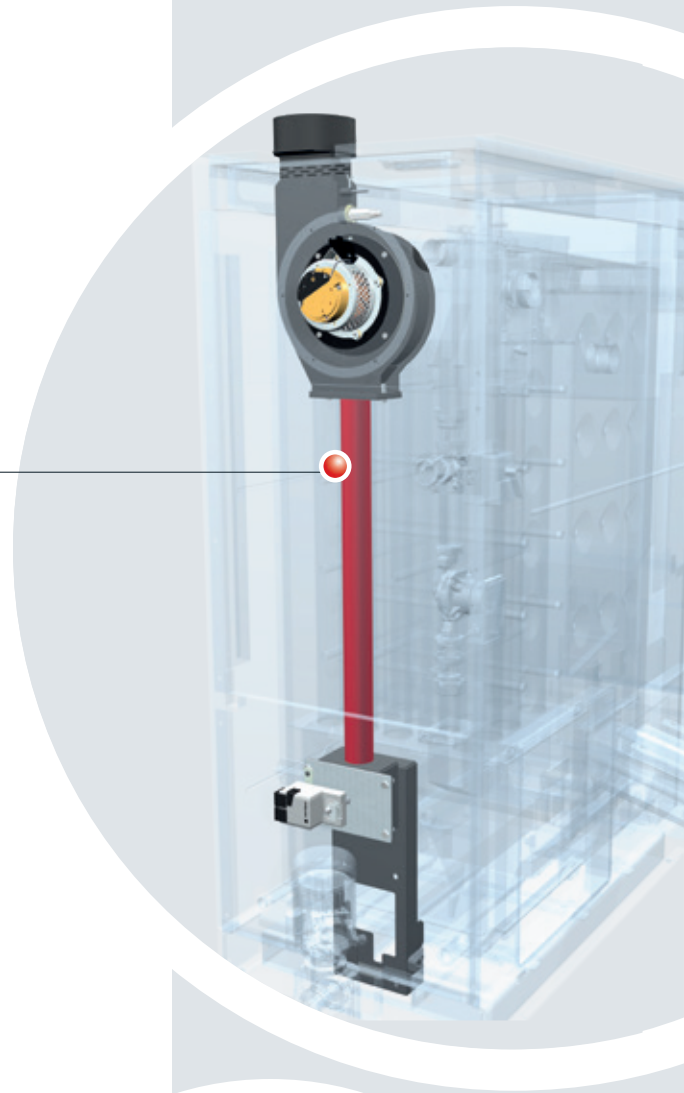

Optional integrated particle separator (electrostatic precipitator)

The optionally available particle separator (electrostatic precipitator) can be added at any time without additional space requirement and thereby considerably reduces the fine dust emissions of the boiler. Cleaning is carried out fully automatically in the joint ash box at the front of the boiler.

- Advantages:
- Can be retrofitted on site
 - No additional space required
 - Combined cleaning with heat exchanger optimisation system (WOS)

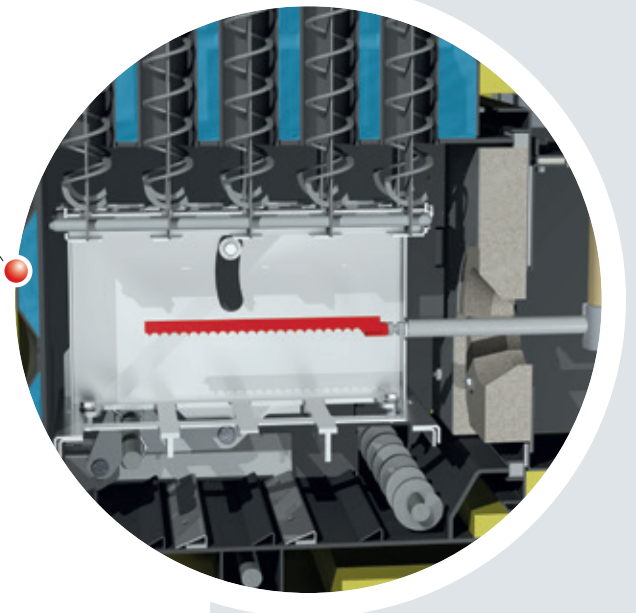

NEW!

Integrated particle separator (electrostatic precipitator) can be added at any time

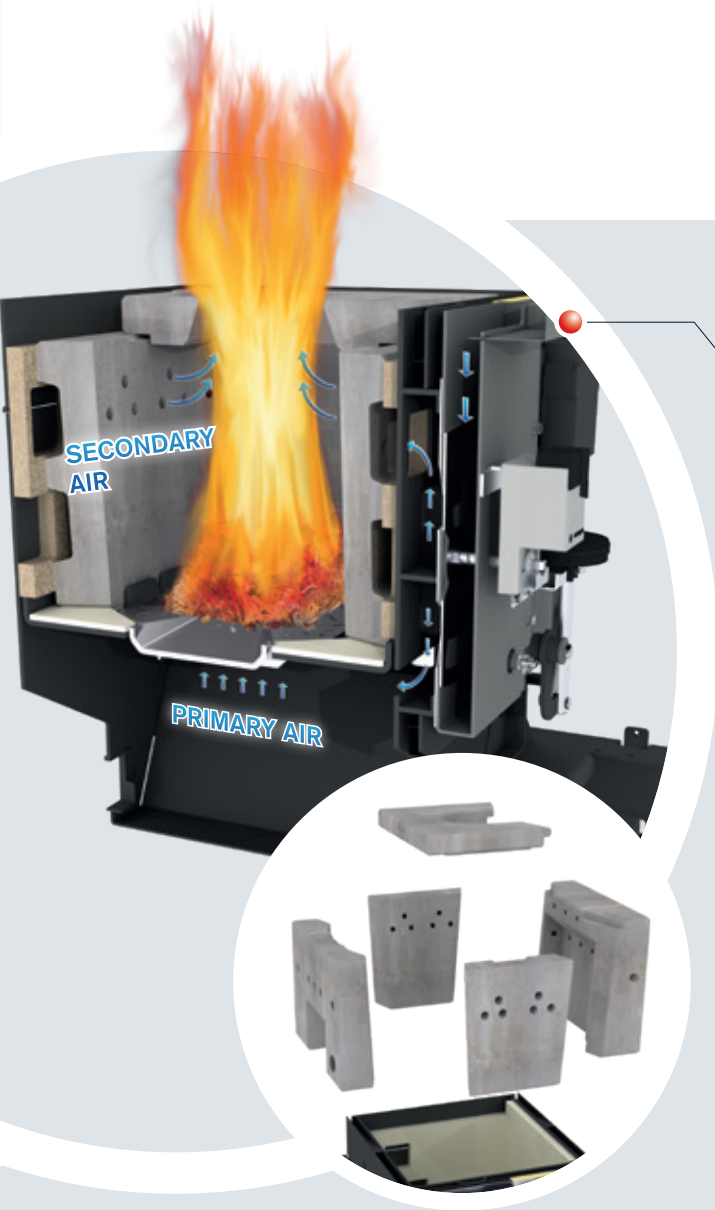

High-temperature silicon carbide combustion chamber and perfect combustion control

The firebricks are made entirely of high-quality fireproof material (silicon carbide). The hot combustion zone ensures optimal combustion and very low emissions.

Patented firebrick!

The patented shaping of the firebrick stones gives the air supply in the combustion chamber particularly good airtightness without the need to use expensive wearing seals. The new shape of the stones also considerably simplifies the maintenance of the combustion chamber as they can be removed easily.

- Advantages:**
- Highest temperature resistance for a long service life
 - Optimum emission values
 - Adapts automatically to changing fuel qualities

Ash discharge system with separate ash screws and ash rakes

Ash is automatically emptied from the combustion chamber and the heat exchanger into the ash container using two separate ash screws, which are powered by a communal geared motor. This ensures a clear separation and absolute tightness between the combustion chamber and the heat exchanger and eliminates the risk of air leaks. The ash screws are speed controlled. The boiler automatically generates a warning message when the ash box is too full.

At the same time, the joint geared motor drives the ash rake (tested for many years in Froeling large-scale boiler systems) in the lower reversing chamber, which transports the heat exchanger ash reliably to the side ash screw.

- Advantages:**
- Optimal emptying
 - No risk of air leakage thanks to twin-chamber ash container
 - Just one common drive

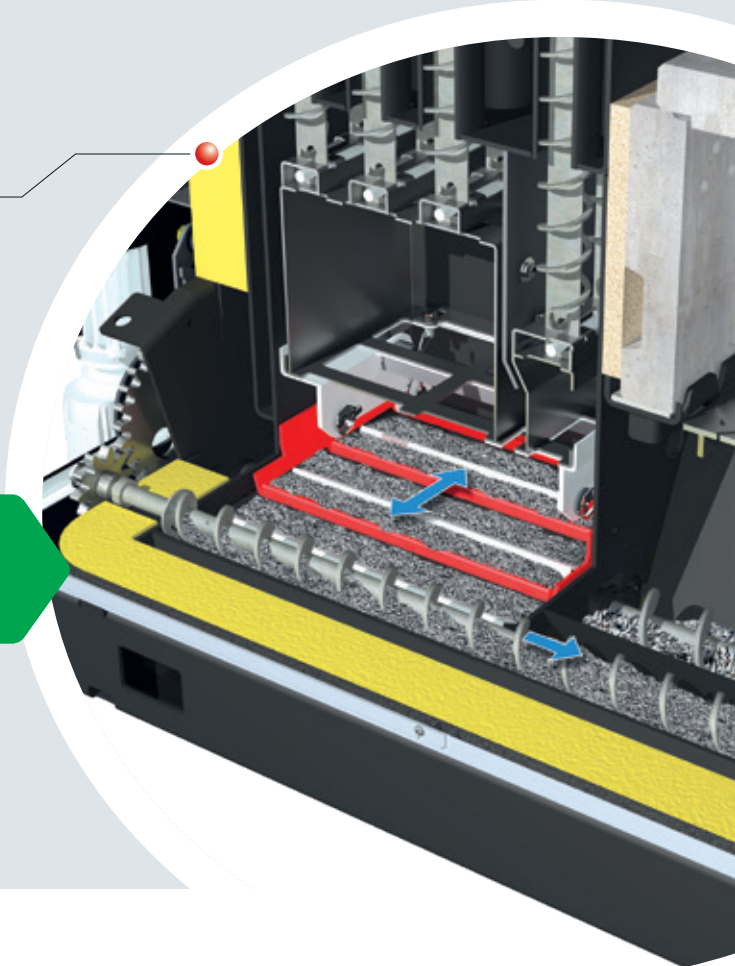

SPECIAL TIPPING GRATE TECHNOLOGY WITH 110° TIPPING GRATE INCLINATION



Two-part combustion grate consisting of a fixed insertion zone and automatic tipping grate guarantee energy-saving operation and lowest emissions.

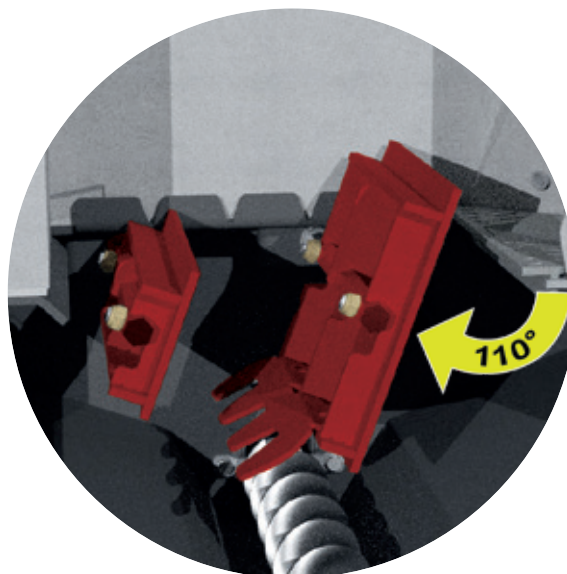

Due to the 110° inclination, the ash is completely emptied from the tipping grate and discharged into the large-volume mobile ash container by means of the ash screw.

CALCULATING THE FUEL REQUIREMENT

The fuel requirement depends on the fuel quality. The following rule of thumb can be used to make a rough estimate: **1 m³ per kW heating load**

Pellets fuel data

Length	3.15 - 40 mm
Diameter	6 mm
Water content	max. 10%
Bulk weight	approx. 650 kg/m ³
Ash content	max. 0.5%
Energy content	4.9 kWh/kg



EXTRA CONVENIENCE WITH THE EXTERNAL ASH BOX

With automatic ash removal, the ash is fed into an external ash container. The clever locking mechanism makes it quick and easy to remove the ash container.

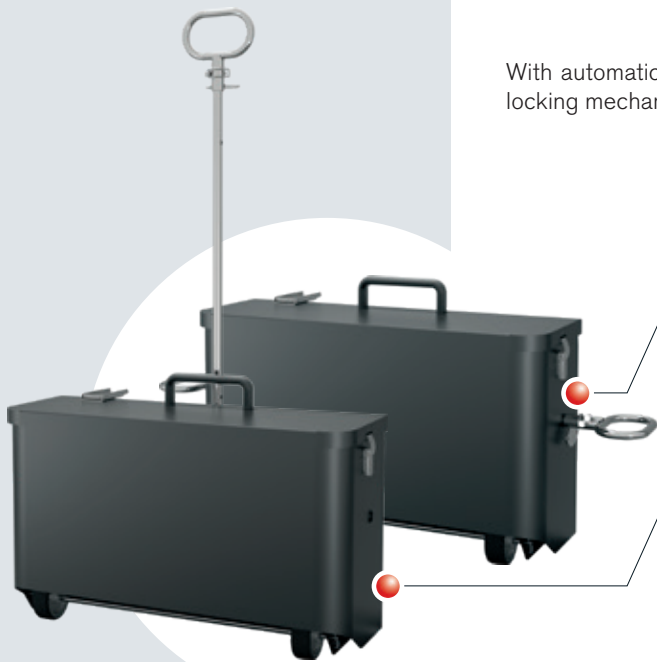

Side carrying handles for quick handling

Easy removal by means of transport rollers

The side carrying handles also allow the ash box to be transported comfortably by pallet forks (e.g. a front loader, forklift truck, etc.)

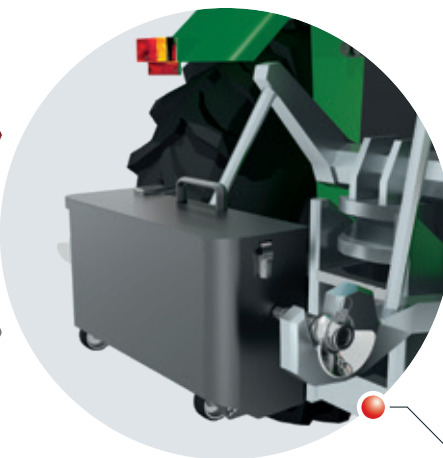

Practical hydraulic device for transporting with the tractor and easy emptying (tipping)



Optional: Ash discharge system with bin

For added convenience, ash can optionally be emptied into a standard 240 l dustbin or flap-bottomed container. The ash is automatically conveyed into the dustbin/flap-bottomed container where it can be easily emptied. This ensures long emptying intervals and maximum convenience.

4 probe manual suction system

The RS 4 manual pellet suction system creates more space in your fuel store. Thanks to the fact that the suction probes are flexible in terms of location, it is possible to make optimal use of every room shape. The switchover between suction probes is manual. As a rough rule of thumb: Plan for one suction probe for every 1 m² pellet storage area.

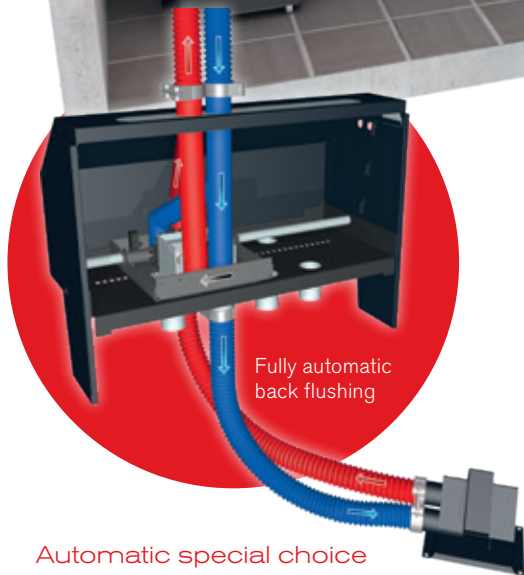

External suction module

An external suction module is used for automatic fuel feed from the fuel store to the pellet container. The suction module can be fitted in any position in the return air line.

Pellet filler pipes

The pellets are delivered by tanker and blown into the store through a filling pipe. The second pipe is used for controlled and dust free removal of the escaping air.

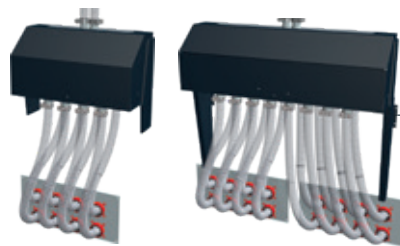

RS 4 / RS 8 pellet suction system

Design as above, however with the difference of automatic switchover between the suction probes.



Advantages at a glance:

- easy to assemble
- no sloping slides necessary in the bunker
- more store space (30%)
- automatic switching between the probes
- automatic back flushing
- maintenance-free system

More information can be found on the Froling brochure "Discharge systems for pellets"

bag silo

The bag silo system is a flexible, simple way of storing pellets. Available in 9 different footprints (from 1.5 m x 1.25 m to 2.9 m x 2.9 m) with a capacity of between 1.6 and 7.4 tonnes, depending on the bulk density. There are other advantages to using a bag silo. It is easy to assemble and dustproof. You can also fit rainproof and sunproof covers and install the silo outside.



Suction screw

The Froling suction delivery system is the ideal solution for rectangular rooms with front-end removal. The deep and horizontal position of the discharge screw means the space in the room is used optimally and complete emptying of the store is guaranteed. Combined with a suction system from Froling it also enables flexible boiler installation.

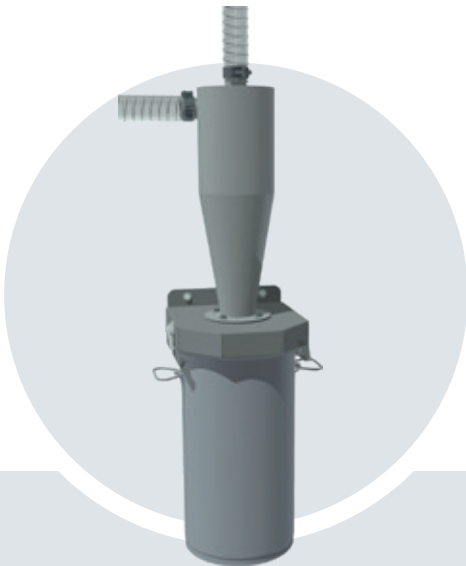

Fuel tuning with the PST pellet deduster

Wood pellets are clean and of very high quality. Any remaining wood dust can be filtered from the fuel using the PST pellet deduster. This optimises the efficiency of the combustion zone over the years. The PST pellet deduster can be fitted in any position in the return air line of the pellet suction system. The suction cyclone design means that the dust particles are separated from the return air and trapped internally. The container is convenient to remove and transport to the emptying point. The system is included in delivery as standard and is maintenance-free.



E3 Pellet Mole®

The E3® pellet mole supplies an annual pellet requirement of several hundred tons to pellet boilers of approx. 50 to 300 kW. A typical store size is around up to 40 tons of pellets or 60m³ capacity in various shapes - from round and square to rectangular, making the E3® pellet mole hugely versatile.

INDIVIDUAL CONTROL UNIT OF THE HEATING SYSTEM

Lambdatronic 3200 control unit

Froeling provides a future-oriented Lambdatronic 3200 and a new 7" touch display. Intelligent control management makes it possible to connect up to 18 heating circuits, up to 4 storage tanks and up to 8 hot water storage tanks. The control unit ensures that the operating statuses are clearly shown. The menu structure is ideally organised to allow easy operation. All essential functions can be selected by simply pressing icons on the large colour display.

- Advantage:**
- Precise combustion control by a Lambda control using a Lambda probe
 - Connection for up to 18 heating circuits, 8 water heaters and up to 4 storage tank management systems
 - Integration capability for a solar panel system
 - LED frame for status display with illuminated presence detection
 - Simple, intuitive operation
 - Various smart home options (e.g. Loxone)
 - Remote control from the living room (remote control RBG 3200 and RGB 3200 Touch) or via Internet (froeling-connect.com)



SIMPLE & INTUITIVE OPERATION

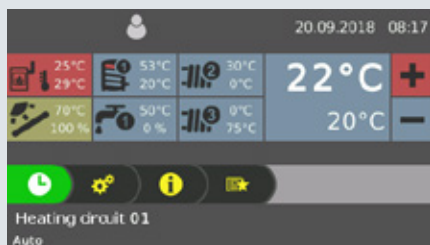

Fig. 1 General overview of heating circuit (start screen)



Fig. 2 View of the heating times (individually adjustable)

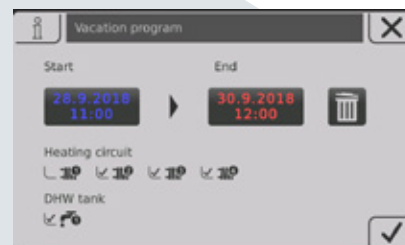

Fig. 3 Overview of the new holiday mode



KEEP TRACK OF EVERYTHING WITH THE FROLING APP

The Froling App allows you to check and control your Froling boiler online from anywhere, at any time. You can read and modify the main status information and settings easily and conveniently online. You can also specify which status messages you want to be informed about via SMS or e-mail (e.g. when the ash box is to be emptied or in the event of a fault message).

Froling boiler (software core module from version V50.04 B05.16) with boiler touch display (from version V60.01 B01.34) a broadband internet connection and a tablet/smartphone with iOS or Android operating system are required. Once the boiler has been connected to the internet and activated, the system can be accessed 24/7 from anywhere using a web-enabled device (mobile, tablet, PC, etc.). The app is available in the Android Play Store and iOS App Store.

NEW! Desktop version
with even more
possibilities.



- Simple and intuitive operation of the boiler
- Status information can be called up and changed within seconds
- Individual naming of the heating circuits
- Changes of status are notified directly to the user (e.g. via e-mail or push notifications)
- No additional hardware required (such as an Internet gateway)

SMART HOME

Enjoy smart, convenient and piece-of-mind living with the Smart Home connection options from Froling.

Loxone

Combine your Froling heating system with the Loxone Miniserver and the new Froling Extension and implement individual boiler control on the basis of the single room control of the Loxone Smart Home.

Advantages: Easy operation and viewing of the heating circuit via the Loxone Miniserver, immediate notification of status changes and individual operating modes for each situation (presence, holiday, economy mode, etc.)

Modbus

Via the Froling modbus interface, the system can be integrated into a building management system.



ACCESSORIES FOR EVEN GREATER CONVENIENCE

FRA room temperature sensor

By using the FRA room temperature sensor, sized just 8x8 cm, the main modes of the corresponding heating circuit can be easily selected and adjusted. The FRA can be connected both with and without affecting the store. The adjusting wheel allows you to change the room temperature by up to $\pm 3^{\circ}\text{C}$.



RBG 3200 room console

For even more convenience you can use the RBG 3200 room console and the new RBG 3200 Touch. You can control the heating system easily from your living room. Important system data is clearly displayed and settings can be changed at the push of a button.



RBG 3200 Touch room console

The RBG 3200 Touch has an impressive touchpad interface. The menu structure means it is intuitive and easy to use. The 17x10 cm console with colour screen shows the most important functions at a glance and automatically adjusts the background lighting to the conditions. The room consoles are connected to the boiler controller using a bus cable.



Heating circuit module

With wall casing and one contact sensor as heating circuit control for up to two mixer heating circuits.



Hydraulic module

With wall casing and two immersion sensors to control one or two pumps and one isolating valve with up to six sensors.



WMZ solar package kit

Set for measuring heat quantity, consisting of a volume pulse transmitter ETW-S 2.5, a collector sensor and two contact sensors for recording flow and return temperatures.



NEW!

FROLING CASCADE CONTROLLER

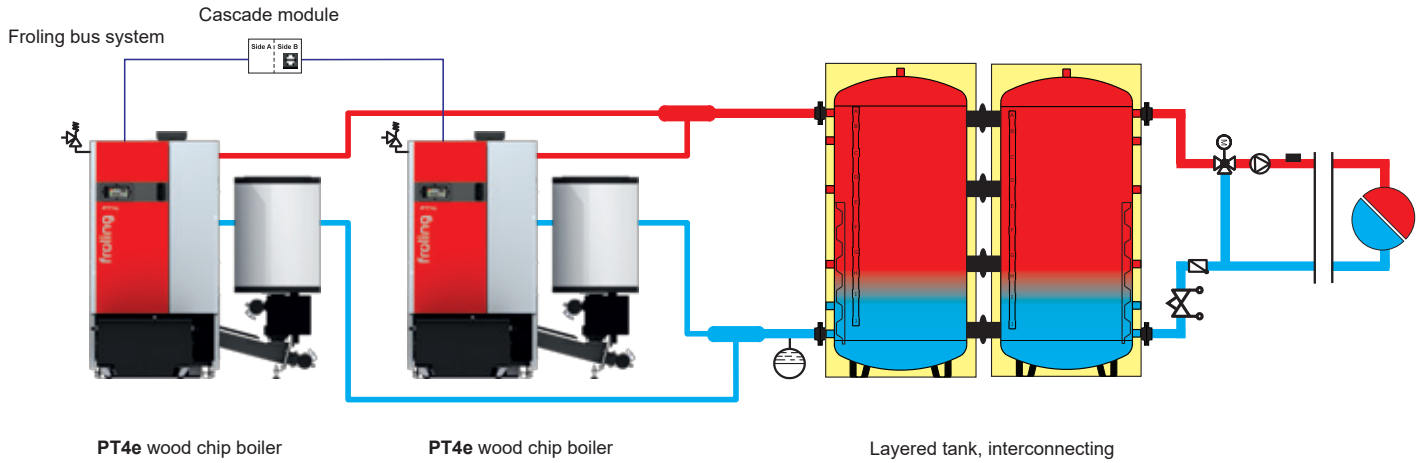

PT4e with layered tank, interconnecting

Heating requirements vary considerably, especially in large buildings such as hotels or public buildings. Froling offers the necessary flexibility with a cascade. This smart solution allows you to combine up to four PT4e wood chip boilers. You can also see the benefits of a cascade during summer months. If the heat requirement is low, one boiler is often sufficient for hot water preparation. This provides a particularly efficient and economical heating solution. A further advantage is the increased reliability of operation, as the heat is provided by several boilers.

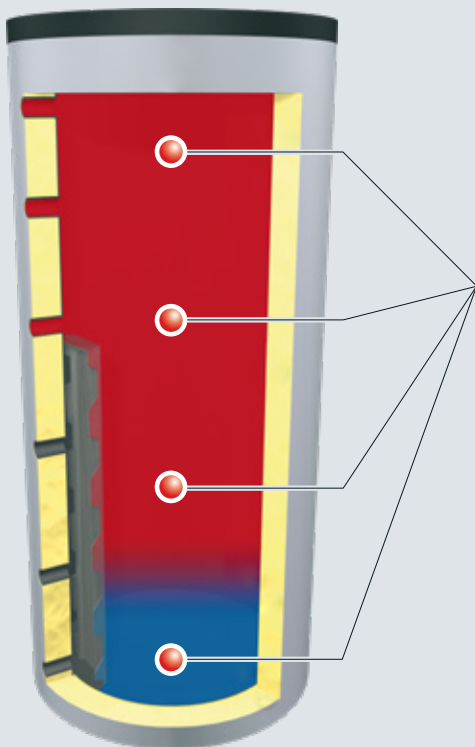

MULTI-SENSOR STORAGE TANK MANAGEMENT

Precise storage tank level with four sensors

In addition to conventional storage tank management with two sensors, Froling also offers the option of multi-sensor storage tank management. For this function four sensors are distributed along the entire height of the storage tank. The controller then uses these to determine the storage tank fill level. The controller can thus quickly identify load changes and adjust the boiler output early on. Fewer start-stop cycles result in a long boiler life and maximise the system efficiency.

- Minimal start-stop cycles
- High system efficiency
- Optimised for cascade systems

TECHNOLOGY SAVES MORE ENERGY

The Froling bus system makes it possible to install extension modules at any location. The local controls can be installed wherever they are needed: at the boiler, at the heat distributor, at the tank, in the living room or in the house next door. Additionally, electric cables are kept to a minimum.

PT4e with multiple house system

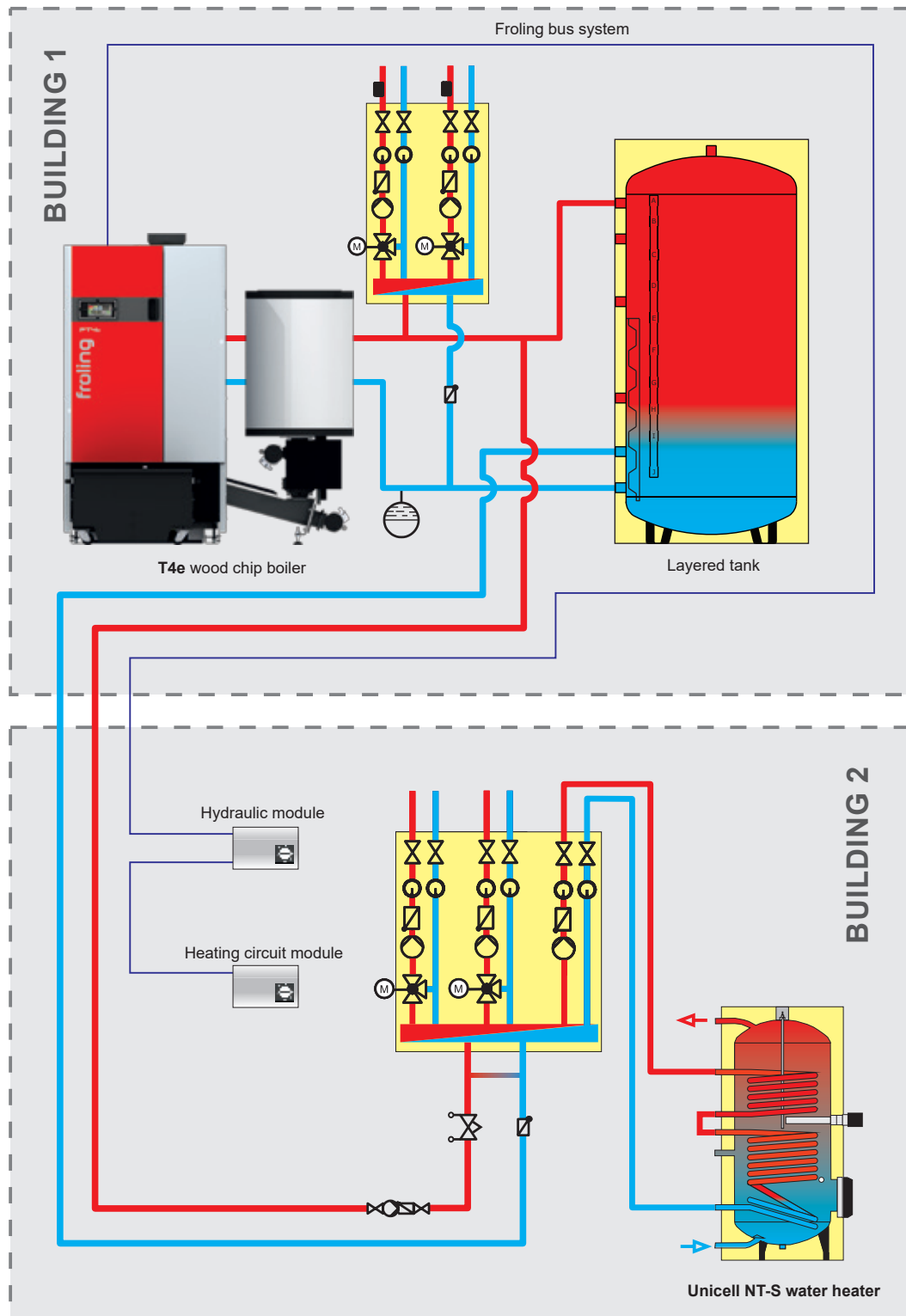

OPERATING AND MAINTENANCE AREAS

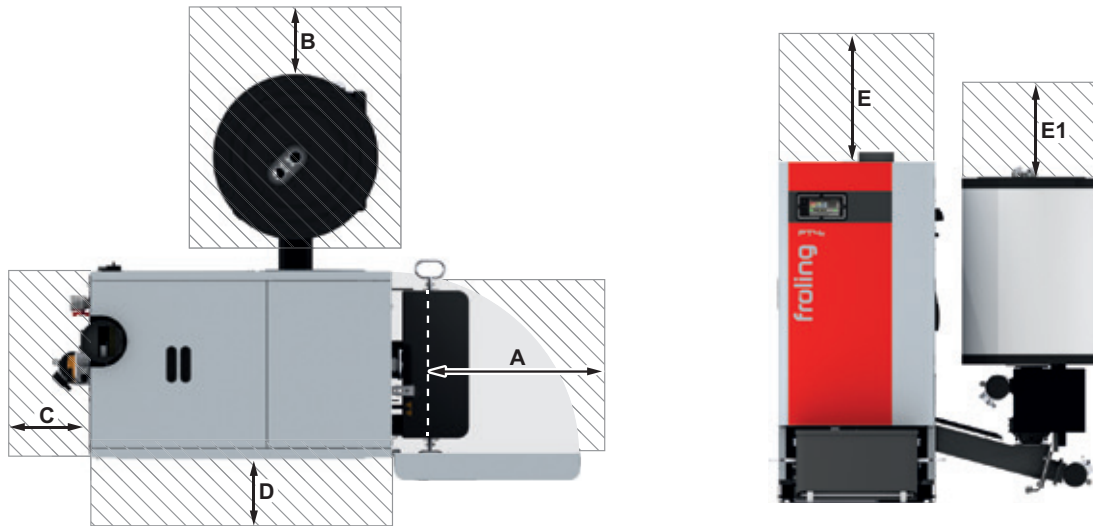

Minimum clearances - PT4e [mm]	120	140	150	160	170
A Insulated door to wall	800	800	800	800	800
B Suction cyclon to wall	300	300	300	300	300
C Back of boiler to wall	500	500	500	500	500
D Side of boiler to wall	150	150	150	150	150
E Maintenance area above the boiler for removing the WOS springs upwards	500	500	500	500	500
E1 Minimum bending radius of the suction hoses	300	300	300	300	300
Minimum store height	2100	2350	2350	2350	2350

	180	200	230	250
A Insulated door to wall	800	900	900	900
B Suction cyclon to wall	300	300	300	300
C Back of boiler to wall	500	500	500	500
D Side of boiler to wall	150	150	150	150
E Maintenance area above the boiler for removing the WOS springs upwards	500	500	500	500
E1 Minimum bending radius of the suction hoses	300	300	300	300
Minimum store height	2350	2500	2500	2500

DIMENSIONS

PELLET BOILER PT4e 120 - 180

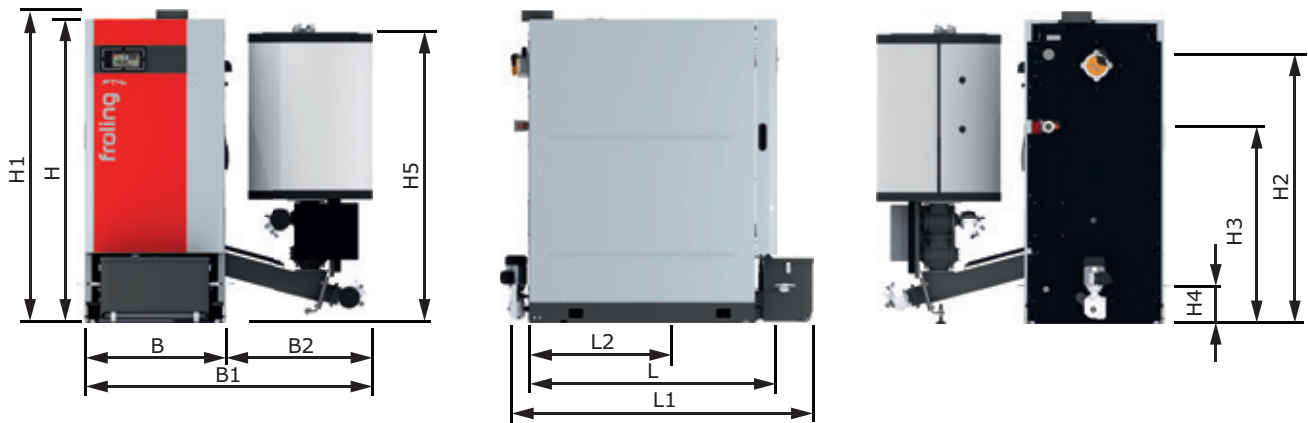

Dimensions [mm]	120	140	150
H Boiler height	1740	1840	1840
H1 Total height including flue gas pipe connection	1790	1895	1895
H1* Optional flue pipe connection	1210	1290	1290
H2 Height, flow connection	1545	1660	1660
H3 Height, return connection with integrated return feed boost	1135	1210	1210
H4 Height, drainage connection	200	200	200
H5 Height of suction unit ¹	1705	1705	1705
B Boiler width	790	790	790
B1 Overall width with suction system	1650	1650	1650
B2 Width of suction system	860	860	860
L Boiler length	1420	1770	1770
L1 Total length incl. ash container	1790	2105	2105
L2 Length, back of boiler to stoker connection	890	1160	1160
Flue pipe diameter	179	199	199
Diameter boiler flow / boiler return	2"	2"	2"
Drainage	1"	1"	1"
	160	170	180
H Boiler height	1840	1840	1840
H1 Total height including flue gas pipe connection	1895	1895	1895
H1* Optional flue pipe connection	1290	1290	1290
H2 Height, flow connection	1660	1660	1660
H3 Height, return connection with integrated return feed boost	1210	1210	1210
H4 Height, drainage connection	200	200	200
H5 Height of suction unit ¹	1705	1705	1705
B Boiler width	790	790	790
B1 Overall width with suction system	1650	1650	1650
B2 Width of suction system	860	860	860
L Boiler length	1770	1770	1770
L1 Total length incl. ash container	2105	2105	2105
L2 Length, back of boiler to stoker connection	1160	1160	1160
Flue pipe diameter	199	199	199
Diameter boiler flow / boiler return	2"	2"	2"
Drainage	1"	1"	1"

¹ Value can be increased by 40 mm (max.) by adjusting the adjustable foot

DIMENSIONS

PELLET BOILER PT4e 200 - 250

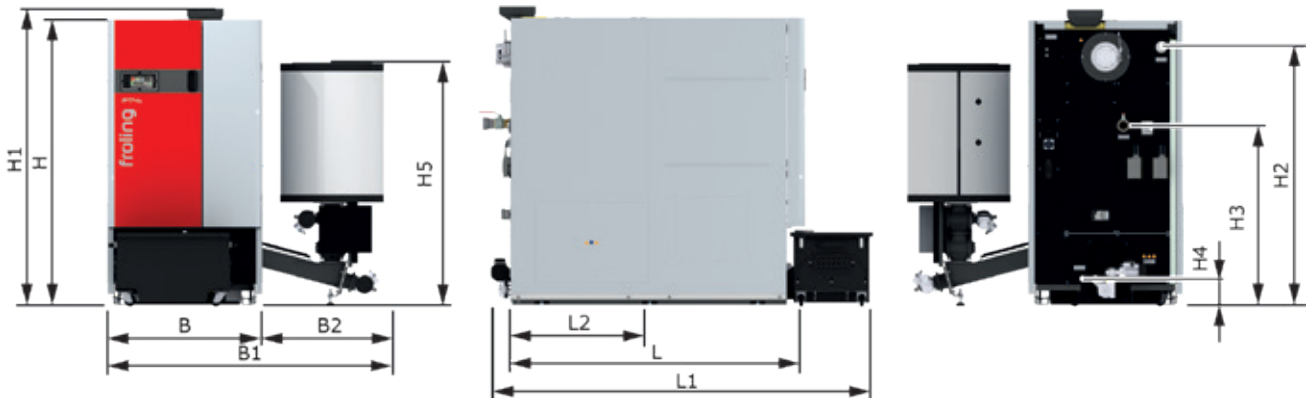

Dimensions [mm]	200	230	250
H Boiler height	1950	1950	1950
H1 Total height including flue gas pipe connection	2025	2025	2025
H1* Optional flue pipe connection	1350	1350	1350
H2 Height, flow connection	1770	1770	1770
H3 Height, return connection with integrated return feed boost	1240	1240	1240
H4 Height, drainage connection	180	180	180
H5 Height of suction unit	1805	1805	1805
B Boiler width	1060	1060	1060
Boiler width without insulation (insertion width)	980	980	980
B1 Overall width with suction system	1800	1800	1800
B2 Width of suction system	740	740	740
L Boiler length	2005	2005	2005
L1 Total length incl. ash container	2550	2550	2550
L2 Length, back of boiler to stoker connection	1310	1310	1310
Flue pipe diameter	249	249	249
Diameter boiler flow / boiler return	2 ½"	2 ½"	2 ½"
Drainage	1"	1"	1"

TECHNICAL SPECIFICATIONS

Technical specifications - PT4e		120	140	150
Nominal output	[kW]	120	140	150
Heat output range	[kW]	36 - 120	42 - 140	45 - 150
Electrical connection	[V/Hz/A]	400V / 50Hz / fused C16A		
Power consumption pellet mode NL/PL	[W]	127 / 49	125 / 51	124 / 52
Weight of boiler (including stoker, without water)	[kg]	1308	1641	1641
Boiler capacity (water)	[l]	228	320	320
Maximum boiler temperature setting	[°C]	90	90	90
Permitted operating pressure	[bar]	4	4	4
Permitted fuel as per EN ISO 17225 ¹⁾		Part 2: Wood pellets class A1 / D06		
		160	170	180
Nominal output	[kW]	160	170	180
Heat output range	[kW]	48 - 160	51 - 170	54 - 180
Electrical connection	[V/Hz/A]	400V / 50Hz / fused C16A		
Power consumption pellet mode NL/PL	[W]	123 / 52	123 / 53	122 / 54
Weight of boiler (including stoker, without water)	[kg]	1641	1641	1641
Boiler capacity (water)	[l]	320	320	320
Maximum boiler temperature setting	[°C]	90	90	90
Permitted operating pressure	[bar]	4	4	4
Permitted fuel as per EN ISO 17225 ¹⁾		Part 2: Wood pellets class A1 / D06		
		200	230	250
Nominal output	[kW]	199	230	250
Heat output range	[kW]	59 - 199	69 - 230	75 - 250
Electrical connection	[V/Hz/A]	400V / 50Hz / fused C16A		
Power consumption pellet mode NL/PL	[W]	120 / 55	146 / 55	162 / 55
Weight of boiler (including stoker, without water)	[kg]	2500	2500	2500
Boiler capacity (water)	[l]	438	438	438
Maximum boiler temperature setting	[°C]	90	90	90
Permitted operating pressure	[bar]	4	4	4
Permitted fuel as per EN ISO 17225 ¹⁾		Part 2: Wood pellets class A1 / D06		

¹⁾Detailed information on the fuel is included in the operating instructions, in the section on "Permitted fuels"

The ecodesign requirements according to VO (EU) 2015/1189, Annex II, point 1. are met.

NOTES

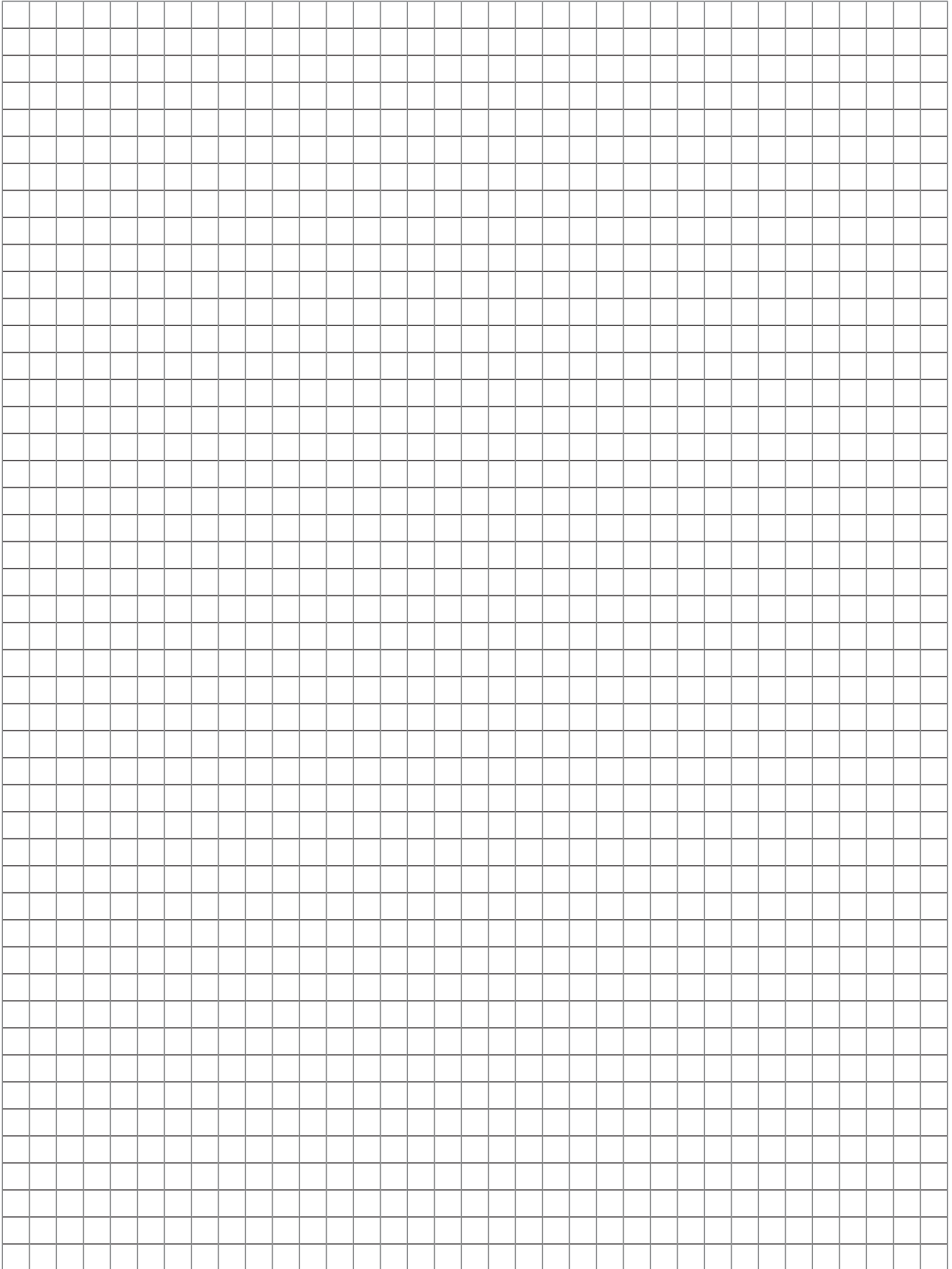



Pellet boiler

PE1 Pellet	7 - 35 kW	P4 Pellet	48 - 105 kW
PE1c Pellet	16 - 22 kW	PT4e	120 - 250 kW



Firewood boiler

S1 Turbo	15 - 20 kW
S3 Turbo	20 - 45 kW
S4 Turbo	22 - 60 kW

Dual fuel boiler

SP Dual compact	15 - 20 kW
SP Dual	22 - 40 kW



Wood chip / Large boilers

T4e	20 - 350 kW	TI	350 kW
Turbomat	150 - 550 kW	Lambdamat	750 - 1500 kW

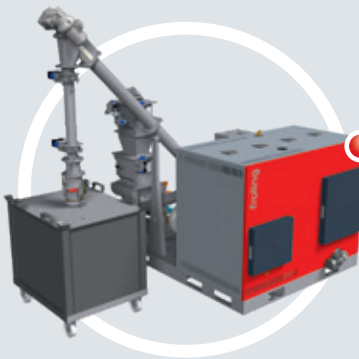

Wood combined heat and power

Fixed-bed gasifier CHP	45 - 500 kWel
------------------------	---------------

Your Fröling partner

Fröling Heizkessel- und Behälterbau Ges.m.b.H.
A-4710 Grieskirchen, Industriestr. 12

AT: Tel +43 (0) 7248 606-0
Fax +43 (0) 7248 606-600

DE: Tel +49 (0) 89 927 926-0
Fax +49 (0) 89 927 926-219

E-mail: info@froeling.com
Internet: www.froeling.com