

T4e

WOOD CHIP BOILER



- Integrated particle separator (electrostatic precipitator) available as an option
- Online boiler control via app
- 7" touch display with LED status display



BETTER HEATING

INNOVATIVE AND
CONVENIENT

froling 



ENVIRONMENTALLY
RESPONSIBLE HEATING,
ECONOMICALLY ATTRACTIVE



Wood chips are a local and environmentally-friendly fuel which is not subject to the crises and fluctuations of the market. Furthermore, wood chip production provides jobs for local residents.

That is why wood chip is the perfect fuel, not just from an economic perspective but also from an environmental point of view. The quality class is determined by the type of wood used.

For sixty years Froling has specialised in the efficient use of wood as a source of energy. Today the name Froling stands for modern biomass heating technology. Froling firewood, wood chip and pellet boilers are successfully in operation all over Europe. All of our products are manufactured in our factories in Austria and Germany. Froling's extensive service network ensures that we can handle all enquiries quickly.

GUARANTEED QUALITY AND RELIABILITY FROM AUSTRIA

- International pioneer in technology and design
- Sophisticated fully automatic operation
- Excellent environmental compatibility
- Environmentally responsible energy efficiency
- Renewable and CO₂-neutral fuel
- Ideal for all types of house
- Up to 5 year Froling-warranty (subject to warranty conditions)

User-friendly, compact, economical and safe:
The new T4e from Froling meets all your needs.

With the silicon carbide combustion chamber, the T4e ensures a **high level of efficiency** (up to 96.3%) with **very low emissions**. Well-planned use of energy-saving EC drives ensures **extremely low energy consumption**.

Thanks to its modular construction and compact dimensions, the Froling T4e is particularly easy to position and install. The entire boiler comes fully assembled, electrically wired and tested.

Particular attention was paid to energy efficiency, durability and stability during the development of the T4e. The T4e consumes very little electricity during operation, keeping the operating costs down. This priority was clearly confirmed when the boiler was awarded the EnergieGenie prize.

The **"EnergieGenie Innovation Prize"** of the Federal Ministry of Agriculture, Forestry, Environment and Water Management and the State of Upper Austria recognises new products according to the criteria of innovation, energy savings and the degree of innovation.

The **"Plus X Award"** honours high-quality innovations that make life simpler and more enjoyable while respecting the environment. Froling's T4e wood chip boiler stood out in the categories for **innovation, high quality, ease of use, functionality and ecology**.



T4e WOOD CHIP BOILER

SYSTEMATIC CONVENIENCE

Flue pipe also available with rear connection (optional)

Speed-controlled, highly efficient EC induced draught fan for lowest power consumption



Optional integrated particle separator (electrostatic precipitator)

Volume-optimised Ø 200 mm twin-chamber rotary valve for burn back protection

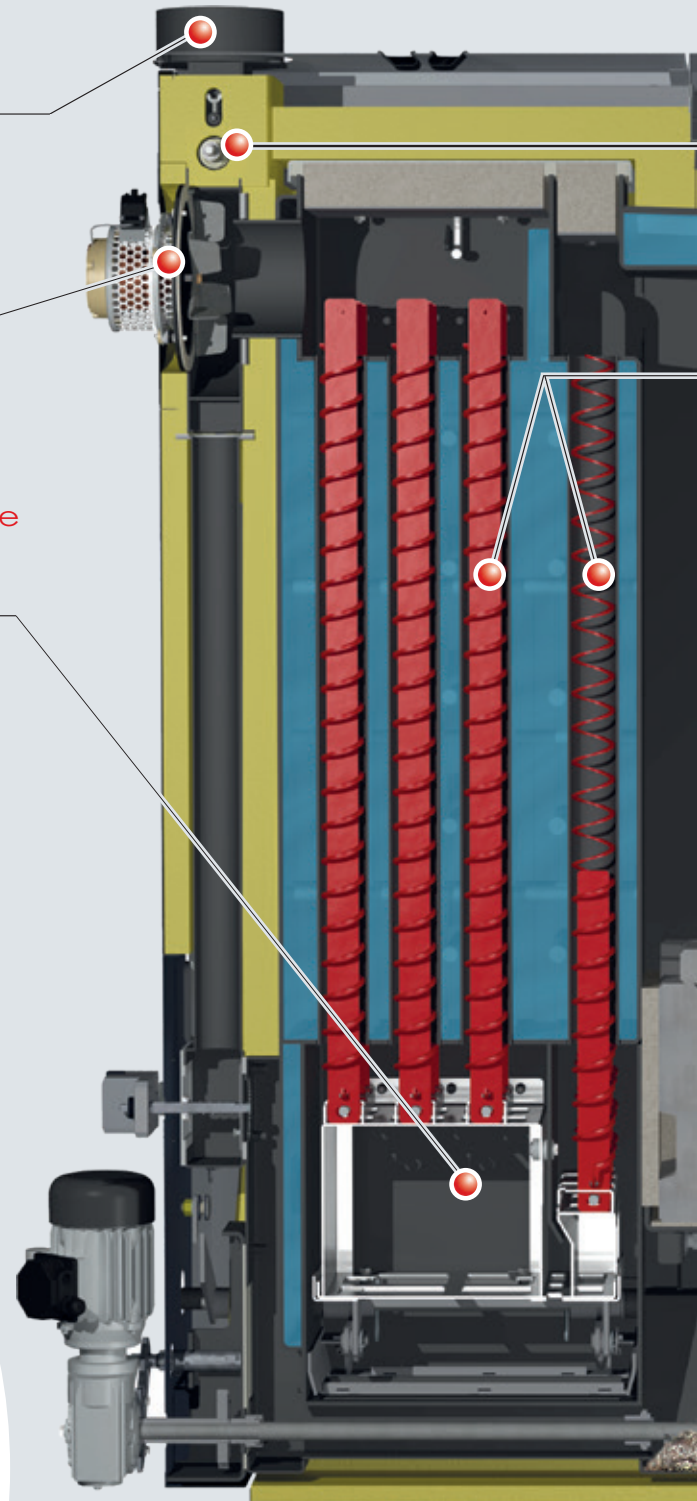
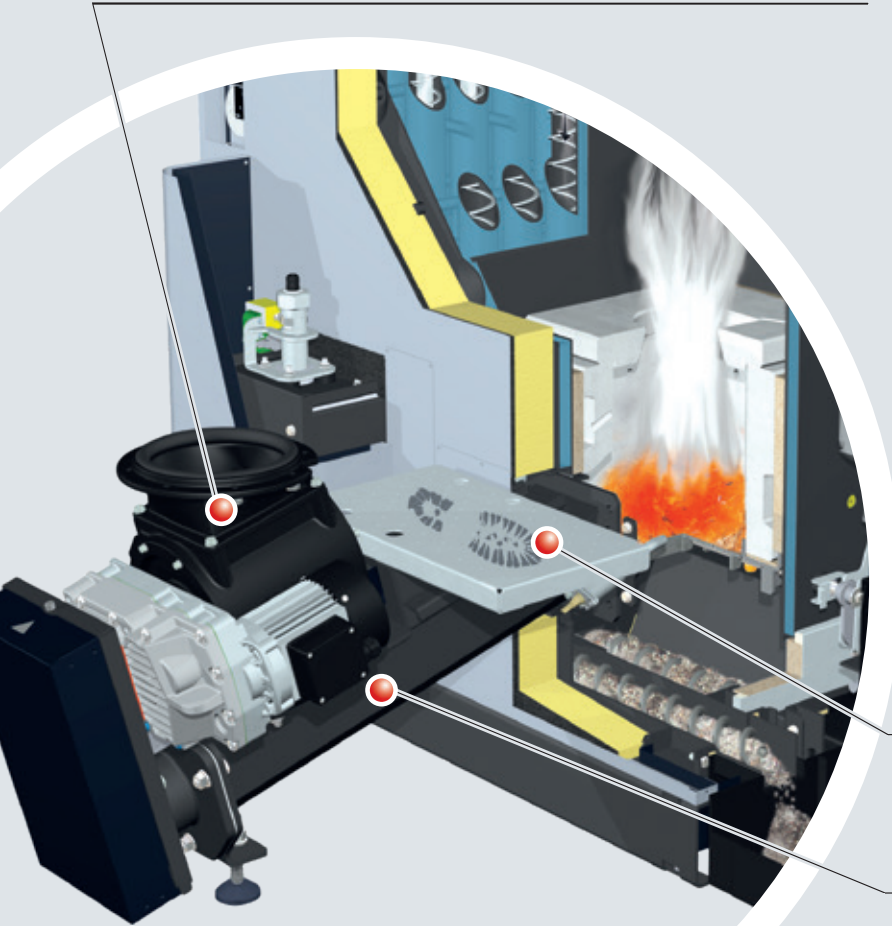

Sturdy foot step for easy maintenance and assembly (up to T4e 180 kW)

Stoker with large Ø100 mm screw and Ø150 mm screw from 200/250 kW

NEW!

7" touch display with LED status illumination

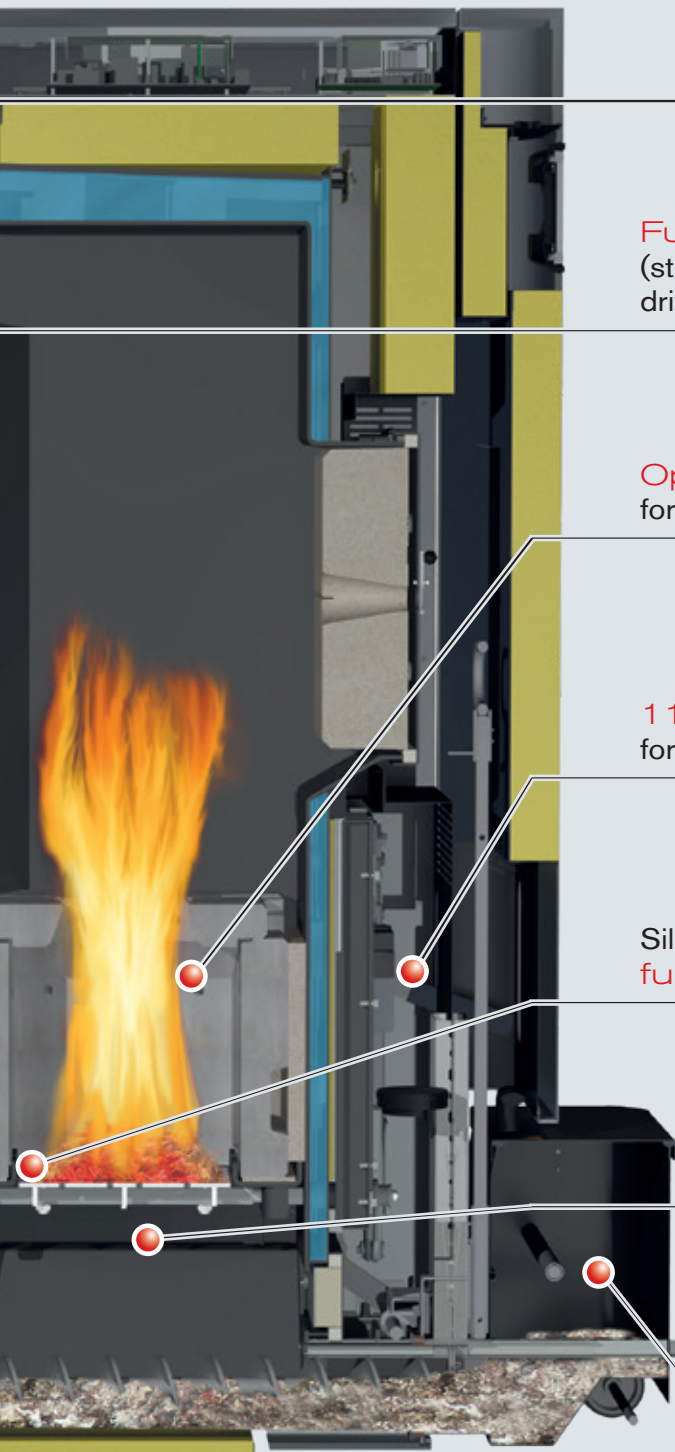

Lambda probe for optimum fuel adjustment

Fully automatic cleaning of all heat exchanger pipes (starting from the first pass) by means of turbulators (mechanical drive in the "cold" area)

Optimized silicon carbide combustion chamber for lowest emissions and a long service life

1 10° tipping grate with 900N drive for optimal grate cleaning

Silent, energy-efficient ceramic igniter with function monitor

Underpressure-controlled combustion with sensorless bed of embers monitor

Fully automatic ash removal with energysaving combi drive (common drive for heat exchanger and combustion chamber ash screw) to large-sized ash containers

FGR (flue gas recirculation) prepared in the boiler, motor and connecting pipe for activation available as an option

WELL PLANNED HOME FOR MORE CONVENIENCE

Easy to assemble on site

The T4e is supplied assembled and wired, you just need to fit the stoker unit and connect the chosen discharge system to the rotary valve. This saves time and money. Thanks to the well-planned layout of the units and its compact design, the T4e can also be used in very confined spaces.

- Advantages:**
- Quick installation
 - Pre-wired
 - Stoker unit can be ordered on the left or right as desired
 - Return temperature control already integrated (ex works)

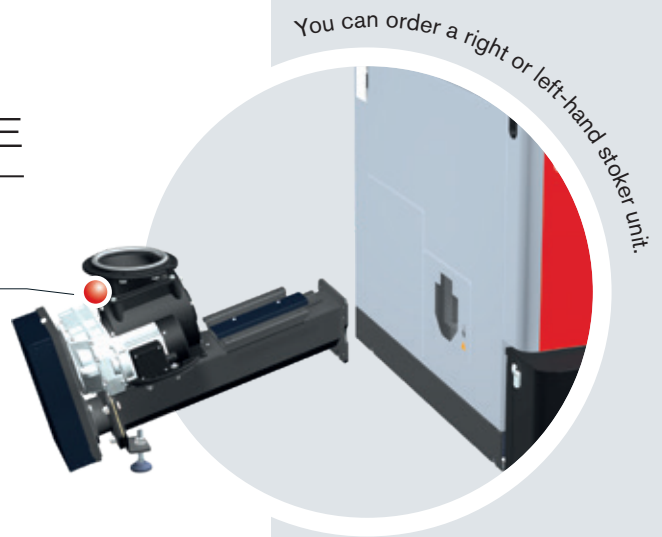

Speed regulated EC induced draught fan

The speed-regulated EC induced draught fan ensures the exact air quantity for combustion. As the induced draught fan is speed-regulated, it stabilises combustion throughout and adjusts the air quantity to the output of the respective material. Working together with the lambda control, it ensures optimum combustion conditions. The EC induced draught fan has a significantly higher efficiency than conventional induced draught fans with AC motors. This results in significant power savings, especially in partial load conditions.

- Advantages:**
- Maximum ease of use
 - Continuous optimisation of combustion
 - Up to 40% less power consumption

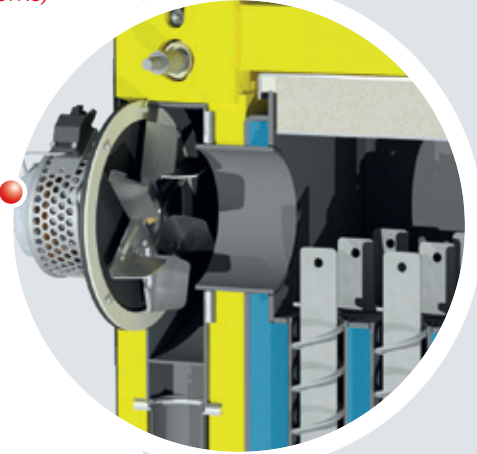

Precise primary and secondary air control

Combustion in the T4e is controlled by underpressure. Combined with the EC induced draught fan, this guarantees extremely high operating safety. The innovative control of air distribution in the combustion zone is a new feature. Primary and secondary air are optimally adjusted to the conditions in the combustion chamber with only one actuator. This, combined with the lambda controller which comes as standard, ensures that emissions are kept to a minimum.

Fast, energy-saving ignition

The silent ceramic igniter ensures safe and energy-saving ignition of the fuel. Thanks to the hot combustion zone, after short periods in idle mode the fuel is automatically reignited by the residual embers. It is only necessary to start the igniter after longer combustion pauses.

- Advantages:**
- Silent ceramic igniter for reliable ignition
 - Automatic combustion of residual embers
 - No separate blower fan required

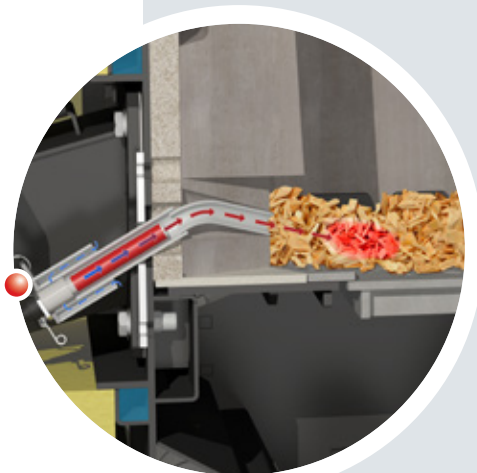

Cleaning of all heat exchanger pipes



Heat exchanger with automatic cleaning (WOS) of all passes and lower drive

The WOS (Efficiency Optimisation System) consists of special turbulators, which are placed in the heat exchanger pipes (**NEW! Now from first pass**) and allow automatic cleaning of the heating surfaces. Clean heating surfaces ensure greater efficiency and thus fuel savings.

- Advantages:
- Greater efficiency
 - Fuel economy
 - Drive mechanism in cold zone (low thermal load)

Permanently integrated return temperature control

The room temperature control integrated as standard avoids unnecessary radiant heat loss; this special feature guarantees maximum efficiency. An external return temperature control is therefore no longer necessary and saves installation time. The components are intelligently built-in and the main parts (e.g. pump) are visible from the outside and easily accessible.

- Advantages:
- Minimum radiant heat loss
 - Maximum efficiency
 - No external return temperature control required
 - Saves space in the boiler room

Balancing valve

- Advantages:
- Optimal hydraulic balancing of the heating system

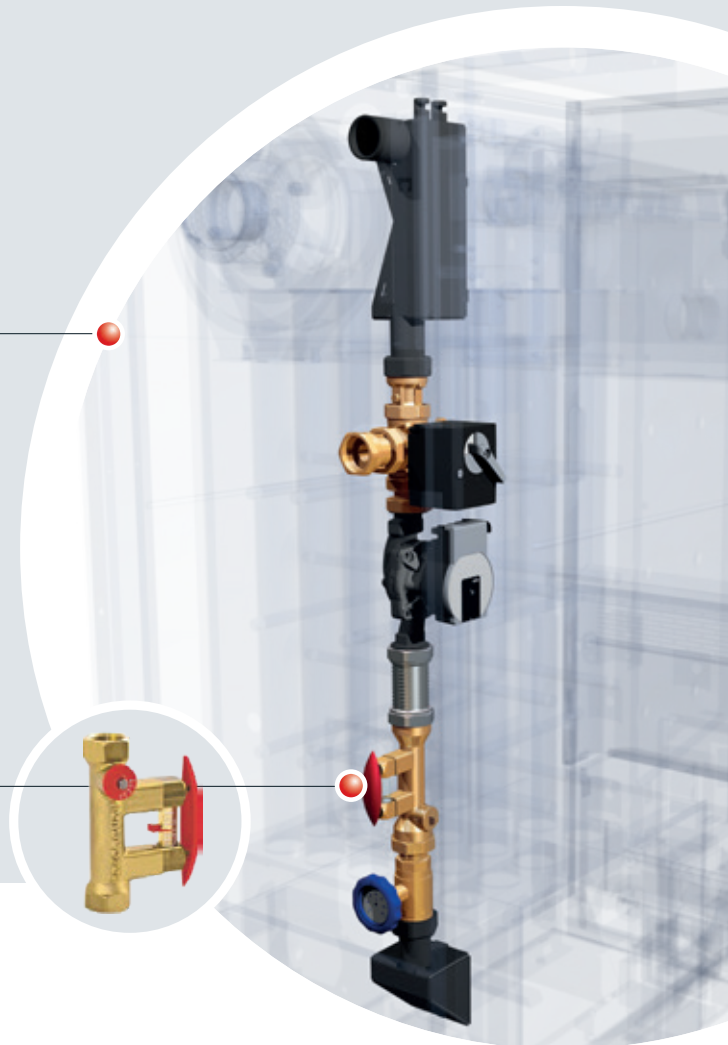

T4e

INTELLIGENT DESIGN DOWN TO THE LAST DETAIL

Flue gas recirculation (FGR) (optional)

The flue gas recirculation system (FGR) mixes part of the flue gas with the combustion air and returns it to the combustion zone.

The FGR optimises combustion and performance, and also reduces NO_x emissions. The lower combustion temperatures offer added protection for flame-swept parts.

- Advantages:
- Precise adjustment via air actuators
 - Ideal combustion conditions
 - Intelligent control of air quantity

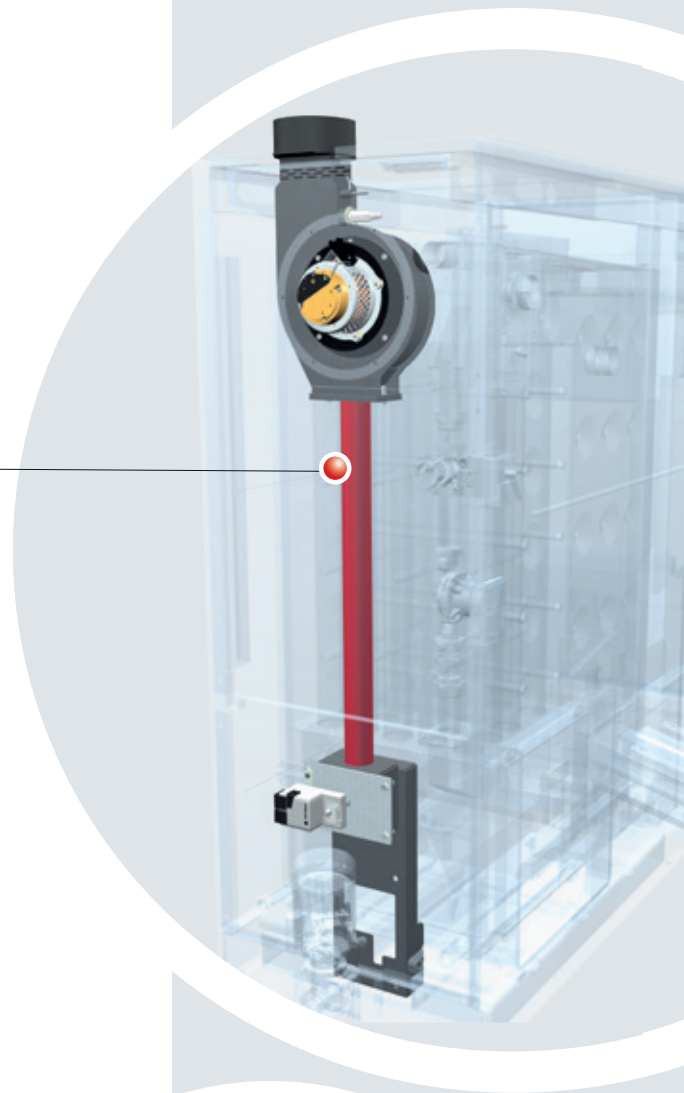

Optional integrated particle separator (electrostatic precipitator)

The optionally available particle separator (electrostatic precipitator) can be added at any time without additional space requirement and thereby considerably reduces the fine dust emissions of the boiler. Cleaning is carried out fully automatically in the joint ash box at the front of the boiler.

- Advantages:
- Can be retrofitted on site
 - No additional space required
 - Combined cleaning with heat exchanger optimisation system (WOS)

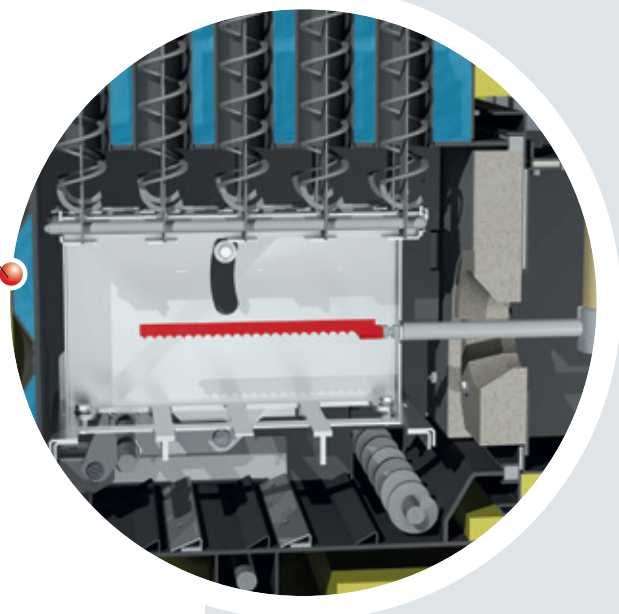

NEW! Integrated particle separator (electrostatic precipitator) can be added at any time



High-temperature silicon carbide combustion chamber and perfect combustion control

The firebricks are made entirely of high-quality fireproof material (silicon carbide). The hot combustion zone ensures optimal combustion and very low emissions.

Patented firebrick!

The patented shaping of the firebrick stones gives the air supply in the combustion chamber particularly good airtightness without the need to use expensive wearing seals. The new shape of the stones also considerably simplifies the maintenance of the combustion chamber as they can be removed easily.

- Advantages:**
- Highest temperature resistance for a long service life
 - Optimum emission values
 - Adapts automatically to changing fuel qualities

Ash discharge system with separate ash screws and ash rakes

Ash is automatically emptied from the combustion chamber and the heat exchanger into the ash container using two separate ash screws, which are powered by a communal geared motor. This ensures a clear separation and absolute tightness between the combustion chamber and the heat exchanger and eliminates the risk of air leaks. The ash screws are speed controlled. The boiler automatically generates a warning message when the ash box is too full.

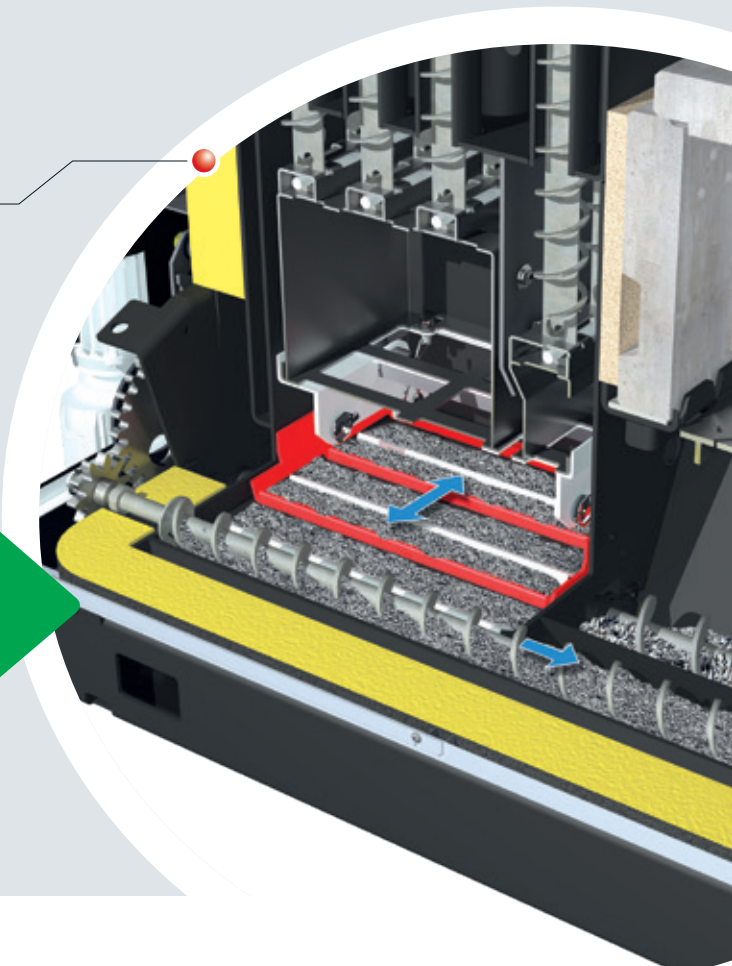

At the same time, the joint geared motor drives the ash rake (tested for many years in Froeling large-scale boiler systems) in the lower reversing chamber, which transports the heat exchanger ash reliably to the side ash screw.

- Advantages:**
- Optimal emptying
 - No risk of air leakage thanks to twin-chamber ash container
 - Just one common drive

SPECIAL TIPPING GRATE TECHNOLOGY

WITH 110° TIPPING GRATE INCLINATION



Two-part combustion grate consisting of a fixed insertion zone and automatic tipping grate guarantee energy-saving operation and lowest emissions.



Due to the 110° inclination, the ash is completely emptied from the tipping grate and discharged into the large-volume mobile ash container by means of the ash screw.



1 tipping grate (20 - 60 kW)

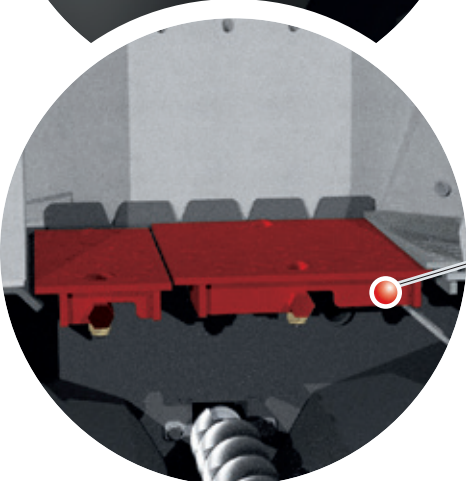

2 tipping grates (80 - 250 kW)

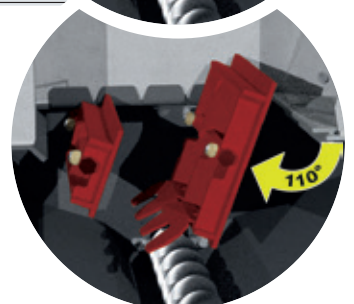
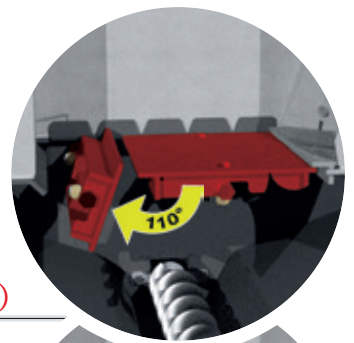

EXTRA CONVENIENCE WITH THE EXTERNAL ASH BOX

With automatic ash removal, the ash is fed into an external ash container. The clever locking mechanism makes it quick and easy to remove the ash container.

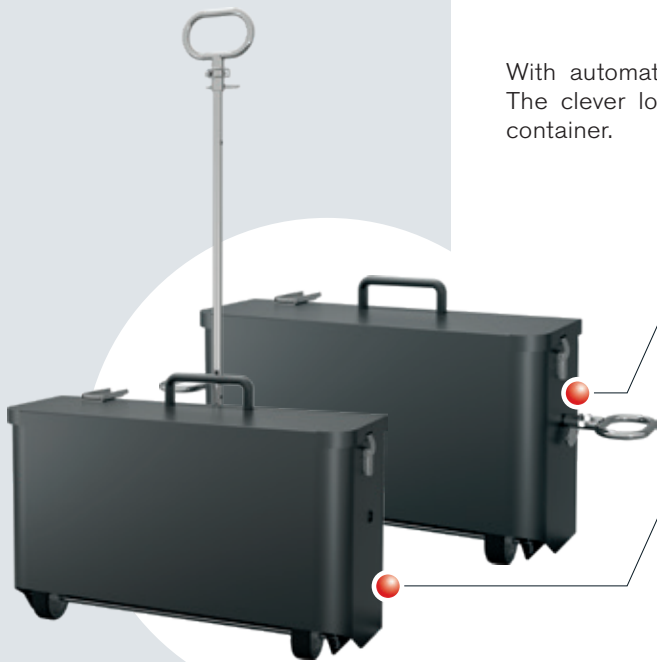

Side carrying handles for quick handling

Easy removal by means of transport rollers

The side carrying handles also allow the ash box to be transported comfortably by pallet forks (e.g. a front loader, forklift truck, etc.).*



Practical hydraulic device for transporting with the tractor and easy emptying (tipping).*

* possible up to T4e 180 kW

Optional: ash discharge system with bin or ash container with open bottom

For added convenience, ash can optionally be emptied into a standard 240 l dustbin or the 330 l container with open bottom. The ash is automatically conveyed into the dustbin where it can be easily emptied. This ensures long emptying intervals and maximum convenience.



Ash discharge system with bin (240 litres)

Ash container with open bottom (330 litres)

OPTIMISED FUEL TRANSPORT

No sloping sides required!

Robust agitator head

Maintenance-free agitator gearbox

Strong spring blades for even fuel transport (for wood chips up to P31S / G50).

Temperature monitoring device in the fuel store (only required in Austria).

Monitored gravity shaft cover

Inspection opening for easy access to the shear edge.

Sturdy stoker screw for reliable fuel feed with automatic turn control.



No sloping sides required

None of Froling's discharge systems requires sloping sides. Without sloping sides, the raising plate fitted to the trough ensures simple operation.

Shear edge

The robust shear plate with cutting edge breaks up larger pieces of fuel guaranteeing continuous fuel feed.

Progressive dosing screw and special trapezoidal duct for minimal force

The plug-in screw system with standard extension pieces between 100 and 2,000 mm (graduations every 100/200 mm) allows easy assembly and flexible positioning of the system in the boiler room.

Special trapezoidal duct

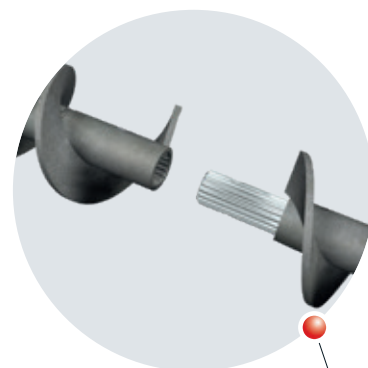
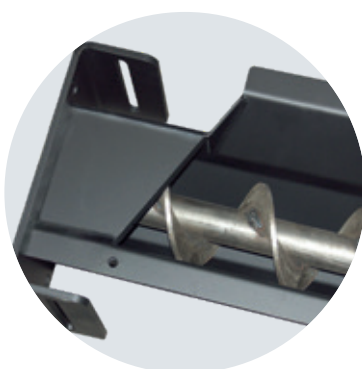
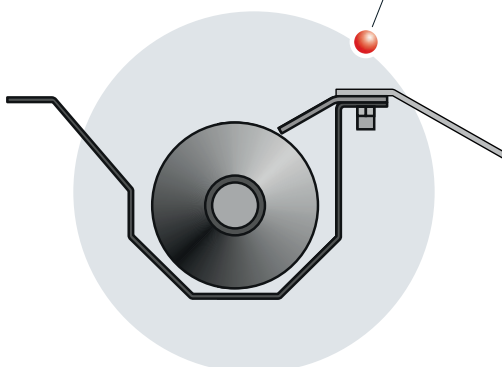

Plug-in screw system



Flexible ball joint

The ball joint is a flexible connecting piece between the discharge screw and the stoker unit. Offering continuous adjustment of the inclinations (up to 15°) and angles, the ball joint allows flexible planning.

High volume rotary valve (Ø 200 mm)

The rotary valve with two large chambers offers maximum burn back protection and continuous material transport.

Highly efficient spur gears

The **powerful, energy-saving spur gears** with a drive power of 0.25 kW ensure that even larger wood chip pieces can be shredded and transported. This design strikes the perfect balance between power and service life.

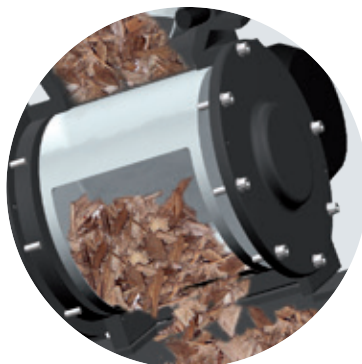

Energy-saving drive motor (only 0.25 kW)

Sturdy stoker unit

The extremely compact stoker unit of the Froling T4e in combination with the rotary valve guarantees maximum burn back protection and reliable fuel feed to the combustion zone. The stoker unit is driven together with the rotary valve by an energy-saving geared motor (highly efficient spur gears with just 0.37 kW power consumption, only 0.55 kW from 80 kW), thus guaranteeing maximum energy efficiency.

The Froling stoker screw with Ø 100 mm or Ø 150 mm (for T4e 200/250) is the optimum solution for safe fuel transport of wood chips up to P31S (previously G50).

- Advantages:
- Flexible set-up
 - Top burn-back protection
 - Low energy consumption
 - Great space saving due to the low design height of the stoker unit

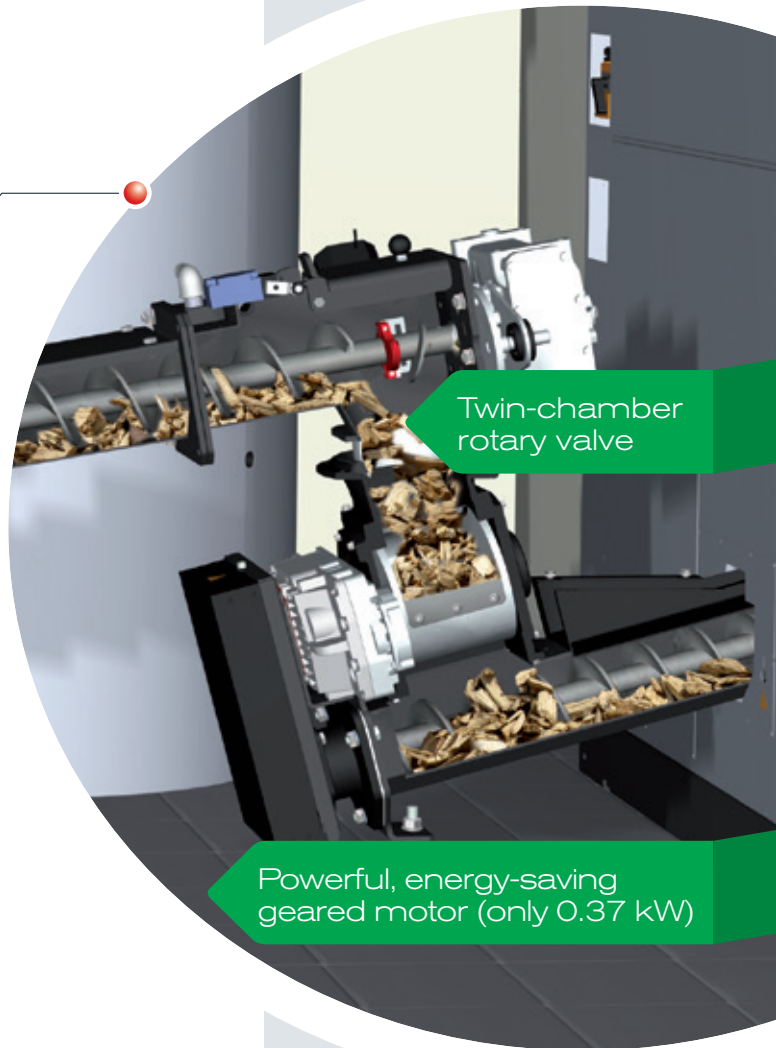

Twin-chamber rotary valve

Powerful, energy-saving geared motor (only 0.37 kW)

Progressive dosing screw with modular plug-in system

The progressive feed screw guarantees reliable fuel transport. Thanks to the progressive screw raise, the material does not get compacted and can always be moved on easily. This ensures less force and energy consumption.

The modular design of the feed screw with standard extension pieces between 100 and 2,000 mm (graduations every 100/200 mm) allows easy assembly and flexible positioning of the system in the boiler room.

The Froling feed screw does not require sloping sides.

- Advantages:
- Flexible set-up
 - Reliable material transport
 - Low energy

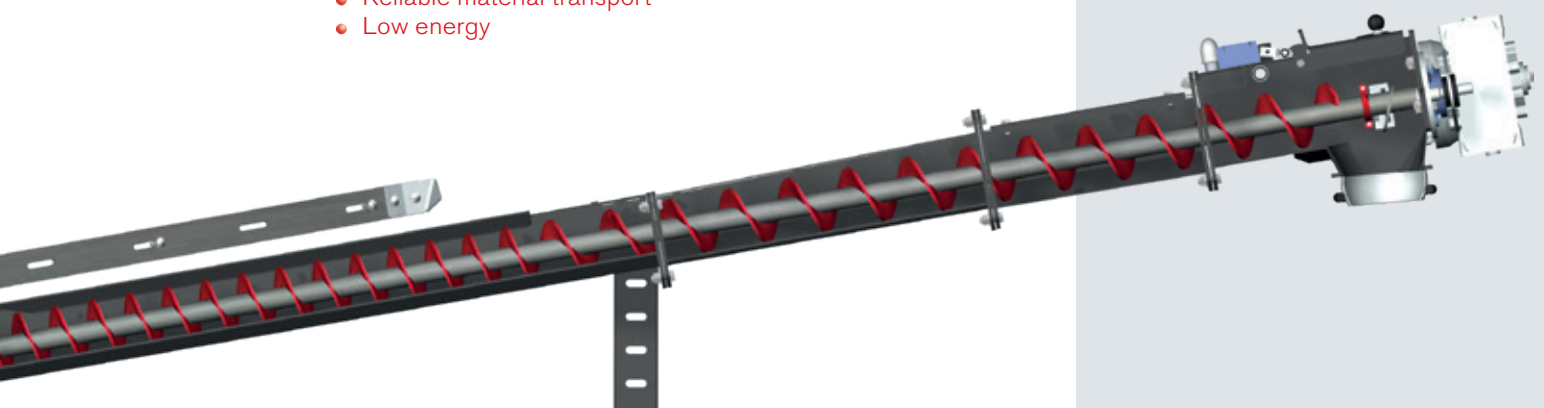



High volume twin-chamber rotary valve

The twin-chamber rotary valve offers maximum operating safety. The rotary valve forms a reliable separation between the discharge system and the feed unit, providing optimal burn back protection. The advanced system design with two spacious chambers ensures that the fuel is transported continuously to the combustion zone. This optimal fuel metering ensures the best possible combustion values.

The rotary valve is extremely quiet and uses only minimal power.

- Advantages:**
- Continuous flow of material
 - Top burn-back protection
 - Suitable for P31S (previously G50) wood chips
 - 200 mm rotor diameter



The two large chambers (200 mm rotor diameter) are especially suitable for transporting wood chips up to P31S (previously G50). High resistance is recognised automatically. The rotary valve and screw move backwards (several times depending on the parameters set) until transport can be re-started.

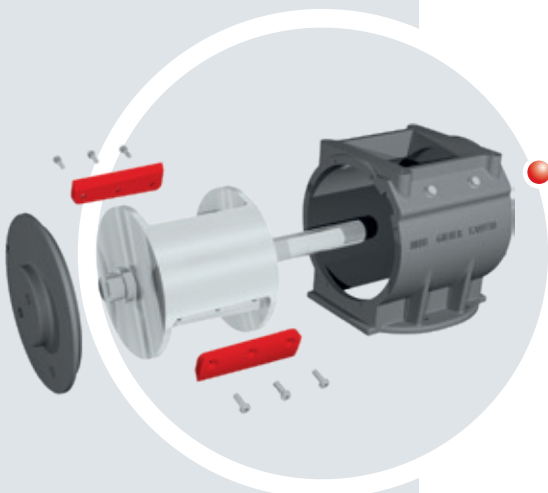

Replaceable blades

The high-quality cutting edges of the blades can also easily cut through coarser pieces of wood chip. The blades both in the rotor and the housing can be simply removed and sharpened if necessary.

ROTARY AGITATOR DISCHARGE SYSTEMS

WITH COMBINED DRIVE

The simple and effective design of Froling's rotary agitator discharge systems ensures smooth operation. Any problematic materials (e.g. foreign bodies) are automatically detected and removed by a reverse turn of the screws (turn control). The feed screw with progressive screw raise ensures low energy consumption.

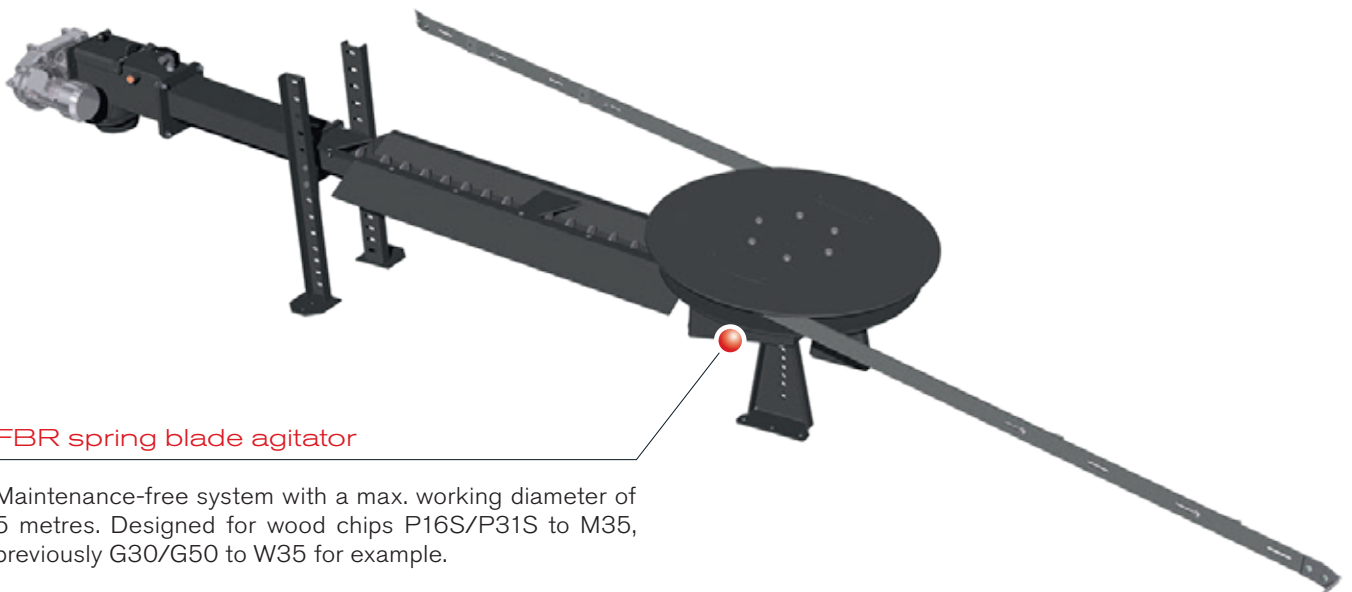

FBR spring blade agitator

Maintenance-free system with a max. working diameter of 5 metres. Designed for wood chips P16S/P31S to M35, previously G30/G50 to W35 for example.

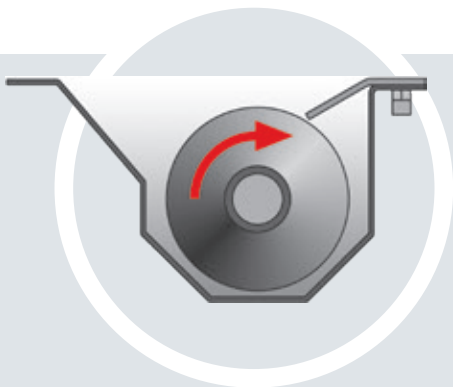

Special trapezoidal duct

The special trapezoidal shape of the trough ensures that fuel is transported smoothly. The system is easy to operate so it saves energy even when feeding in the maximum amount of pellets.



Optional fibre shredder

If the material is particularly fibrous, the optional fibre shredder can shred long parts, thus ensuring reliable transportation of the material.



Rotary agitator arms with tearing hooks

The powerful rotary agitator arms move towards the agitator head during filling and then swing back out when fuel is removed. Together with the sturdy tearing hooks that loosen the fuel, they ensure that the fuel store is emptied.

ROTARY AGITATOR DISCHARGE SYSTEMS WITH SEPARATE DRIVE

Froeling's rotary agitator discharge systems with separate drive offer even greater flexibility. In the FBR-G the rotary agitator is powered independently of the discharge screw. This allows flexible installation and variable adjustment of the feed output. The discharge screws can be positioned on both the left and right of the rotary agitator.



SAMPLE INSTALLATION OPTIONS

One discharge screw on the left

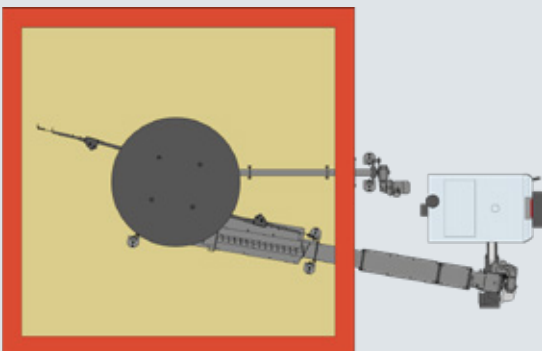

Two discharge screws, one standard, one extra-long

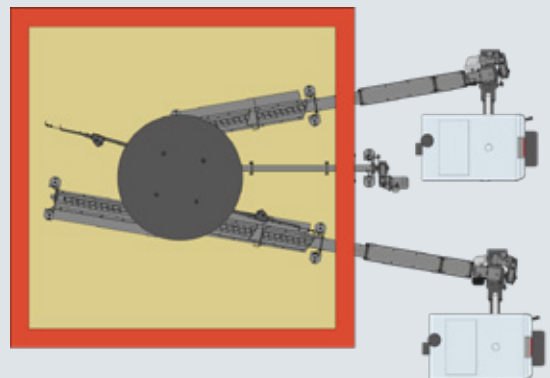

More information in our brochures
„Bunker filling systems“!

Vertical feed screw

Froling's vertical feed screw sets new standards for feed output (up to 40m³/h depending on the wood chips used), operating safety and effective distribution. The wood chips are pushed from the tipping gutter into the vertical feed system with a screw, which transports the fuel to the desired height for the distribution device. In this way, the vertical feed screw enables dust-free filling of the store, guaranteeing even distribution of the fuel.

Also available with
horizontal distributor screw

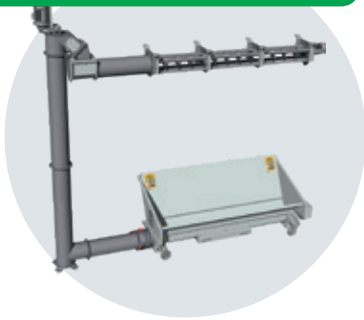

Bunker filling screw

The fuel is transported using the bunker filling screw into the store space via the tipping chute which is located outside the store. The bunker filling screw stops automatically when the bunker is full.

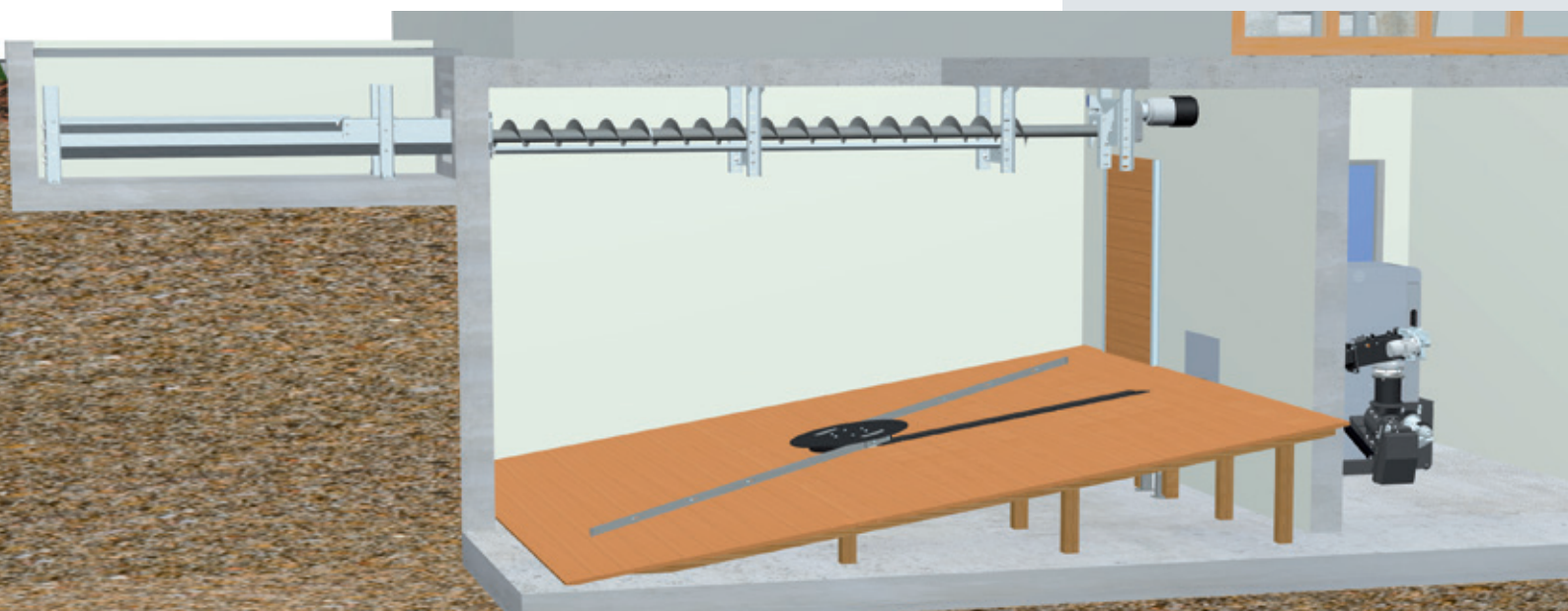

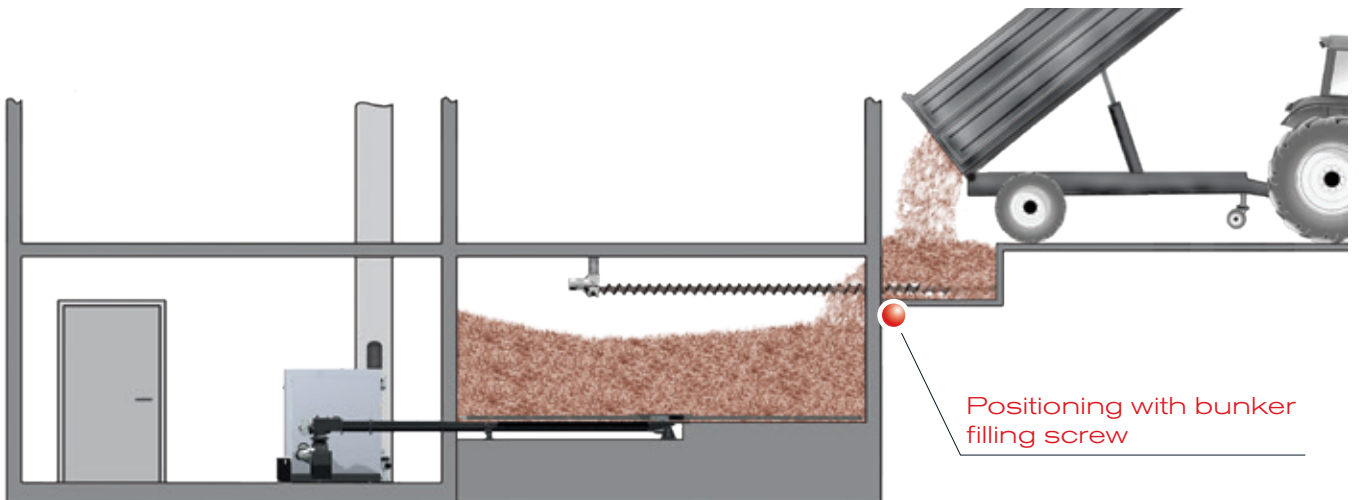
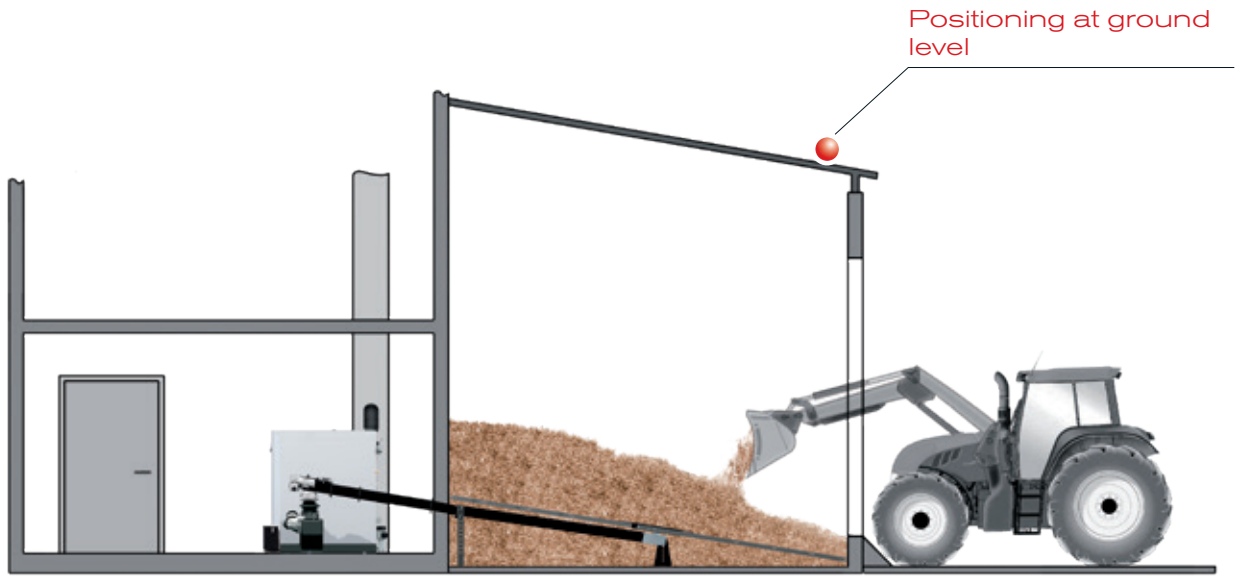

INDIVIDUAL CONTROL UNIT OF THE HEATING SYSTEM

Lambdatronic H 3200 control unit

Fröling provides a future-oriented Lambdatronic H 3200 and a new 7" touch display. Intelligent control management makes it possible to connect up to 18 heating circuits, up to 4 storage tanks and up to 8 hot water storage tanks. The control unit ensures that the operating statuses are clearly shown. The menu structure is ideally organised to allow easy operation. All essential functions can be selected by simply pressing icons on the large colour display.

- Advantages:
- Precise combustion control by a Lambda control using a Lambda probe
 - Connection for up to 18 heating circuits, 8 water heaters and up to 4 storage tank management systems
 - Integration capability for a solar panel system
 - LED frame for status display with illuminated presence detection
 - Simple and intuitive operation
 - Various smart home options (such as Loxone)
 - Remote control from the living room (remote control 3200 and RGB 3200 Touch) or via Internet (froeling-connect.com)



SIMPLE & INTUITIVE OPERATION

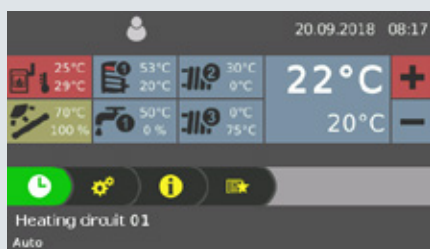

Fig. 1 General overview of the heating circuit (start screen)



Fig. 2 View of the heating times (individually adjustable)

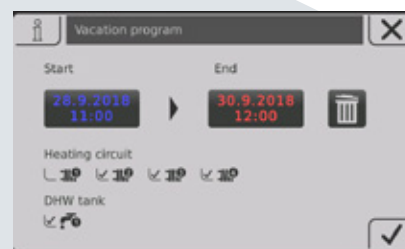

Fig. 3 Overview of the new holiday mode



KEEP TRACK OF EVERYTHING WITH THE FROLING APP

The Froling App allows you to check and control your Froling boiler online from anywhere, at any time. You can read and modify the main status information and settings easily and conveniently online. You can also specify which status messages you want to be informed about via SMS or e-mail (e.g. when the ash box is to be emptied or in the event of a fault message).

Froling boiler (software core module from version V50.04 B05.16) with boiler touch display (from version V60.01 B01.34) a broadband internet connection and a tablet/smartphone with iOS or Android operating system are required. Once the boiler has been connected to the internet and activated, the system can be accessed 24/7 from anywhere using a web-enabled device (mobile, tablet, PC, etc.). The app is available in the Android Play Store and iOS App Store.

NEW! Desktop version
with even more options.

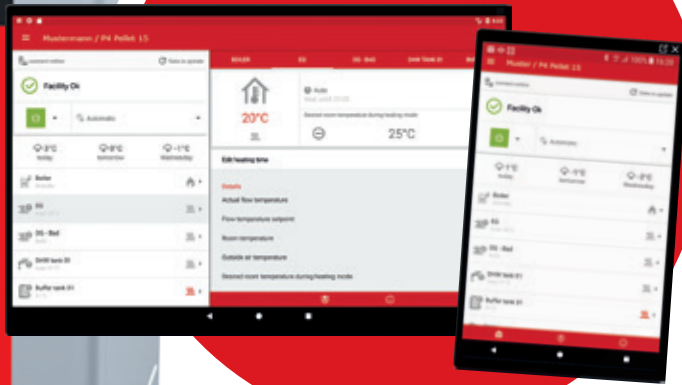

- Simple and intuitive operation of the boiler
- Status information can be called up and changed within seconds
- Individual naming of the heating circuits
- Changes of status are notified directly to the user (e.g. via e-mail or push notifications)
- No additional hardware required (such as an Internet gateway)

SMART HOME

Enjoy smart, convenient and piece-of-mind living with the Smart Home connection options from Froling.

Loxone

Combine your Froling heating system with the Loxone Miniserver and the new Froling Extension and implement individual boiler control on the basis of the single room control of the Loxone Smart Home.

Advantages: Easy operation and viewing of the heating circuit via the Loxone Miniserver, immediate notification of status changes and individual operating modes for each situation (presence, holiday, economy mode, etc.)

Modbus

Via the Froling modbus interface, the system can be integrated into a building management system.



ACCESSORIES FOR EVEN GREATER CONVENIENCE

FRA room temperature sensor

By using the FRA room temperature sensor, sized just 8x8 cm, the main modes of the corresponding heating circuit can be easily selected and adjusted. The FRA can be connected both with and without affecting the store. The adjusting wheel allows you to change the room temperature by up to $\pm 3^{\circ}\text{C}$.



RBG 3200 room console

For even more convenience you can use the RBG 3200 room console and the new RBG 3200 Touch. You can control the heating system easily from your living room. Important system data is clearly displayed and settings can be changed at the push of a button.



RBG 3200 Touch room console

The RBG 3200 Touch has an impressive touchpad interface. The menu structure means it is intuitive and easy to use. The 17x10 cm console with colour screen shows the most important functions at a glance and automatically adjusts the background lighting to the conditions. The room consoles are connected to the boiler controller using a bus cable.



Heating circuit module

With wall casing and one contact sensor as heating circuit control for up to two mixer heating circuits.



Hydraulic module

With wall casing and two immersion sensors to control one or two pumps and one isolating valve with up to six sensors.



WMZ solar package kit

Set for measuring heat quantity, consisting of a volume pulse transmitter ETW-S 2.5, a collector sensor and two contact sensors for recording flow and return temperatures.

NEW!

FROLING CASCADE CONTROLLER

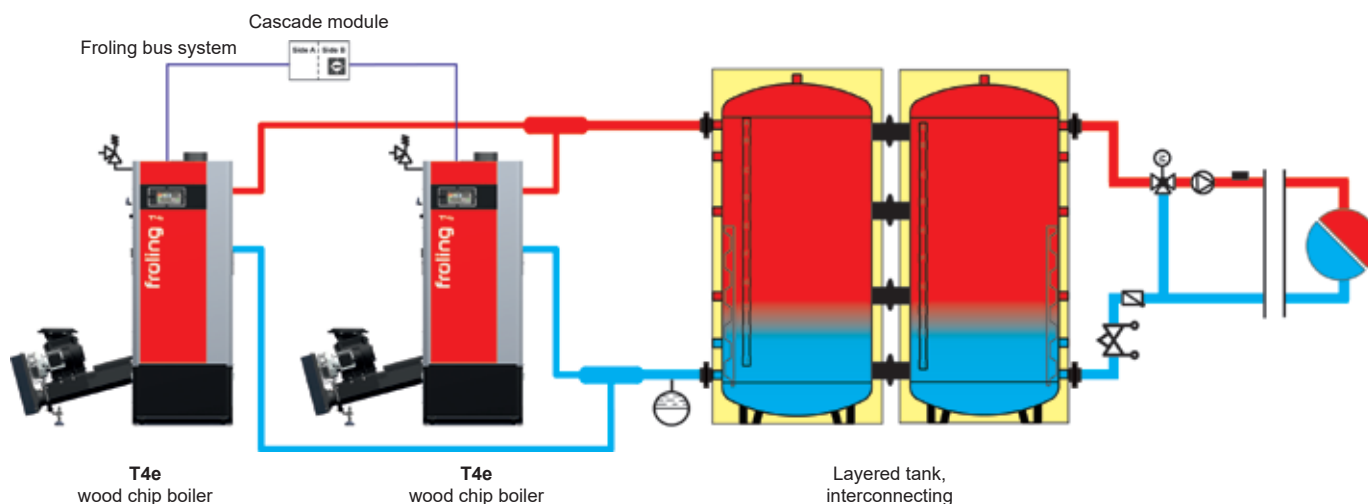

T4e with layered tank, interconnecting

Heating requirements vary considerably, especially in large buildings such as hotels or public buildings. Froling offers the necessary flexibility with a cascade. This smart solution allows you to combine up to four T4e wood chip boilers. You can also see the benefits of a cascade during summer months. If the heat requirement is low, one boiler is often sufficient for hot water preparation. This provides a particularly efficient and economical heating solution. A further advantage is the increased reliability of operation, as the heat is provided by several boilers.

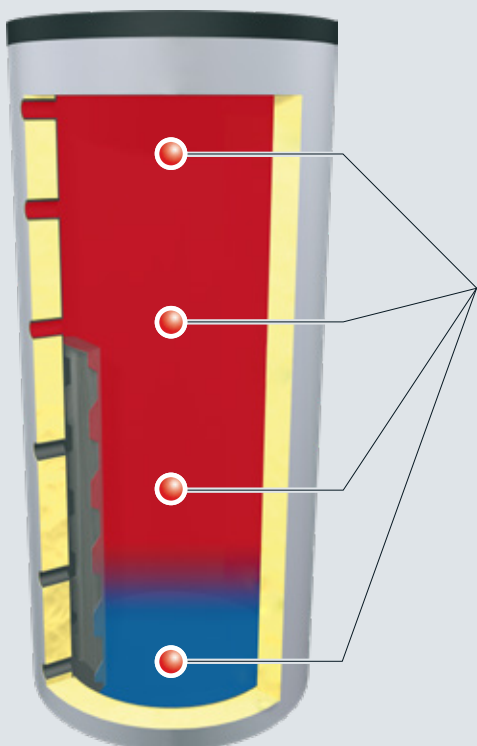

MULTI-SENSOR STORAGE TANK MANAGEMENT

Precise storage tank level with four sensors

In addition to conventional storage tank management with two sensors, Froling also offers the option of multi-sensor storage tank management. For this function four sensors are distributed along the entire height of the storage tank. The controller then uses these to determine the storage tank fill level. The controller can thus quickly identify load changes and adjust the boiler output early on. Fewer start-stop cycles result in a long boiler life and maximise the system efficiency.

- Minimal start-stop cycles
- High system efficiency
- Optimised for cascade systems

TECHNICAL INFORMATION

SAVES MORE ENERGY

The Froling bus system makes it possible to install extension modules at any location. The local controls can be installed wherever they are needed: at the boiler, at the heat distributor, at the tank, in the living room or in the house next door. Additionally, electric cables are kept to a minimum.

T4e with multiple house system

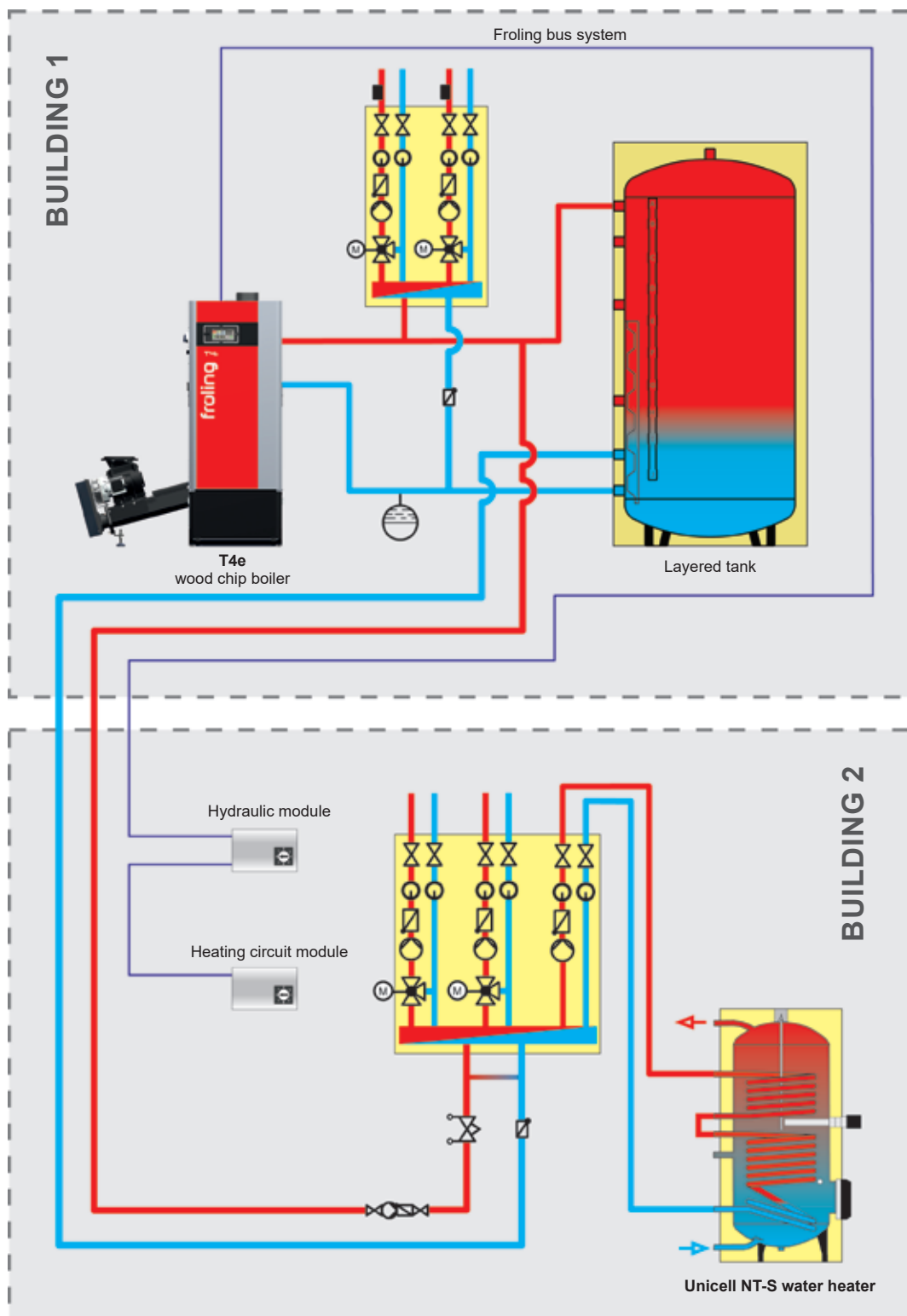

CALCULATING THE FUEL REQUIREMENT



Wood chip fuel specification

P16S woodchips (previously G30)	
Size	3.15 – 16 mm (min. 60%)
Max. length	45 mm
Max. cross-section	2 cm ²
P31S woodchips (previously G50)	
Size	3.15 – 31.5 mm (min. 60%)
Max. length	150 mm
Max. cross-section	4 cm ²
water content	max. 35%
Bulk weight	approx. 210 - 250 kg/bcm
Energy content	3.5 kWh/kg



Pellets fuel data

Length	3.15 - 40 mm
Diameter	6 mm
Water content	max. 10%
Bulk weight	approx. 650 kg/m ³
Ash content	max. 0.5%
Energy content	4.9 kWh/kg

The fuel requirement depends on the fuel quality. The following rule of thumb can be used to make a rough estimate:

Wood chips:

Hardwood P16S/M30 (previously G30/W30):
2.0 bcm per kW heating load
Softwood P16S/M30 (previously G30/W30):
2.5 bcm per kW heating load

Pellets:

1 m³ per kW heating load

Annual wood chip requirement in bulk cubic metres

Source: Bayerische Forstverwaltung

E.g. annual consumption approx. 57,500 kWh (T4e 30 kW, 1,600 full load hours, 93.5% efficiency, wood chips M30 previously W30)

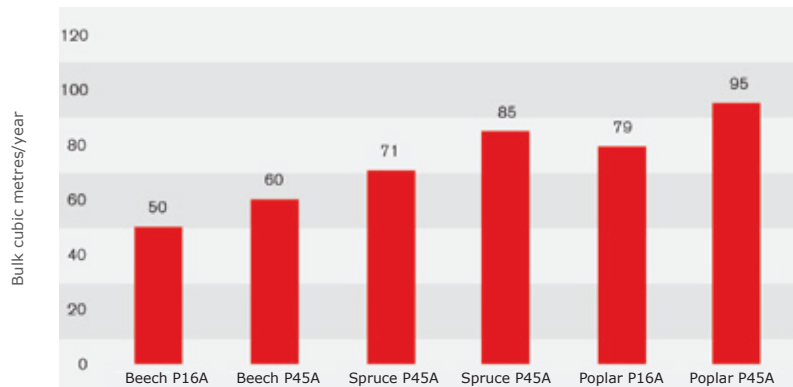

Heating values depending on water content and moisture

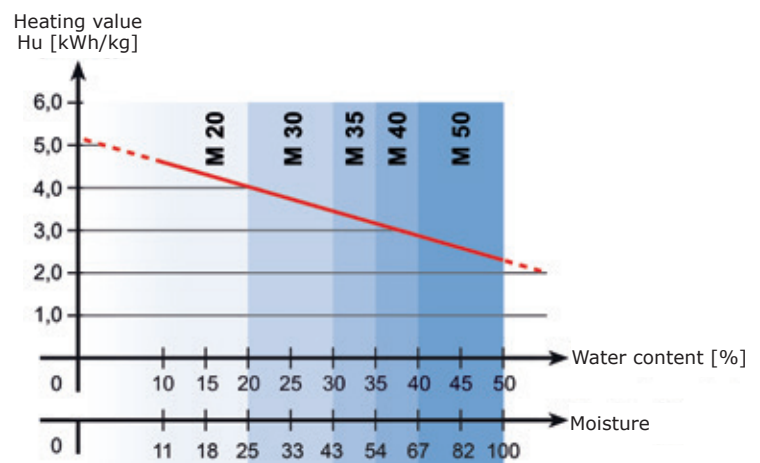

DIMENSIONS T4e

20 - 180 kW

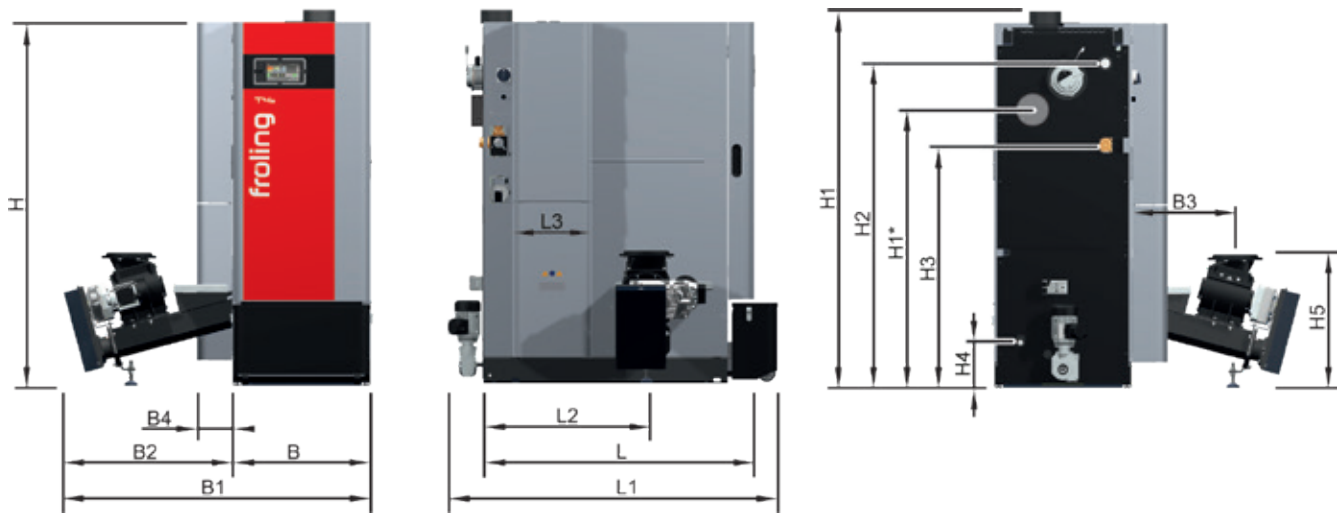

Dimensions [mm]	20 - 35	45 - 60	80 - 110	130 - 180
H Boiler height	1490	1690	1740	1840
H1 Total height including flue gas pipe connection	1545	1745	1790	1895
H1* Optional flue gas pipe connection	960	1160	1210	1290
H2 Height of flow connection	1305	1505	1545	1660
H3 Height of return connection with integrated return feed boost	955	1155	1135	1210
H4 Height of the drainage connection	210	210	200	200
H5 Height of rotary valve connection	615	615	615	615
B Boiler width Width without insulation (width required)	640 -	640 -	790 -	790 -
B1 Total width with stoker unit	1410	1410	1570	1570
B2 Width of stoker unit	770	770	780	780
B3 Distance from boiler side to stoker connection	470	470	480	480
B4 Width of particle separator/electrostatic precipitator (optional)	165	165	165	165
L Length of boiler	1170	1270	1420	1770
L1 Overall length	1475	1550	1795	2105
L2 Length, back of boiler to stoker connection	690	770	890	1160
L3 Length of particle separator/electrostatic precipitator (optional)	370	370	550	715
Flue pipe diameter	149	149	179	199
Diameter boiler flow / boiler return	1 1/4"	1 1/4"	2"	2"
Drainage	1/2"	1/2"	1"	1"

CAUTION: The flow and return connections are located on the stoker side (T4e 20-180). The rear flue pipe connection (optional) is installed on the averted side of the stoker (T4e 20-110). In the case of the T4e 130-180, the rear flue pipe connection (optional) is always on the left side of the boiler.

DIMENSIONS T4e

200 - 350 kW

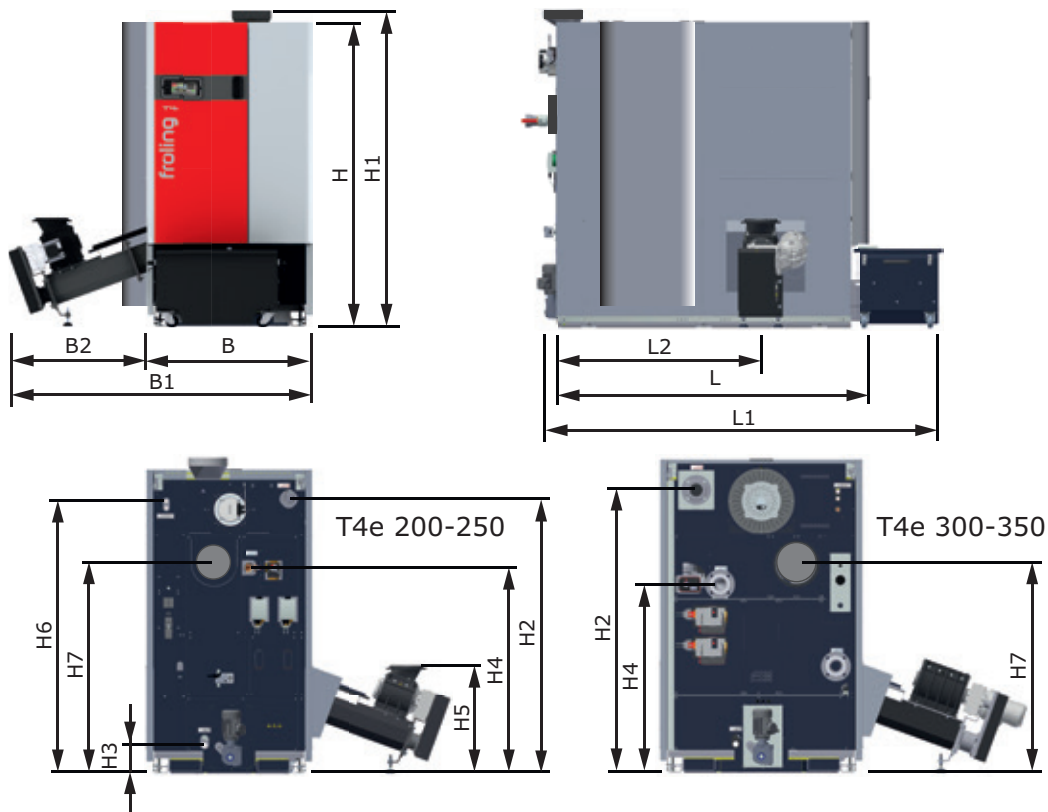

Dimensions [mm]	200 - 250	300 - 350
H Boiler height	1950	1980
H1 Total height including flue gas pipe connection	2025	--
H2 Height of flow connection	1770	1785
H3 Height of the drainage connection	180	180
H4 Height of return connection with integrated return feed boost	1240	1190
H5 Height of rotary valve connection	690	690
H6 Height, safety heat exchanger	1720	1755
H7 Rear flue gas pipe connection (optional for T4e 200 - 250)	1350	1320
B Boiler width	1060	1280
Width without insulation (width required)	980	1195
B1 Total width with stoker unit	1955	2325
B2 Width of stoker unit	890	1045
L Length of boiler	2005	2195
L1 Overall length	2550	2720
L2 Length, back of boiler to stoker connection	1310	1475
Flue pipe diameter	249	249
Diameter boiler flow / boiler return	2 1/2"	DN 80 / PN 6
Drainage	1"	1"

CAUTION:

With the T4e 200-250, the flow and return connections are always on the left-hand side of the boiler, and the flue pipe connection at the back is always on the right-hand side of the boiler. With the T4e 300-350, the flow and return connections are always on the right-hand side of the boiler, and the flue pipe connection at the back is always on the left-hand side of the boiler.

TECHNICAL SPECIFICATIONS

Technical specifications - T4e		20	25	30
Nominal output	[kW]	19,9	25,1	30
Thermal output range	[kW]	5,95 - 19,9	7,51 - 25,1	9 - 30
Electrical connection	[V/Hz/A]	400V / 50Hz / fused C16A		
Power consumption wood chip mode NL/PL	[W]	48 / 39	55 / 39	59 / 39
Power consumption pellet mode NL/PL	[W]	55 / 42	60 / 40	73 / 43
Weight of boiler (including stoker, without water)	[kg]	740	740	740
Boiler capacity (water)	[l]	117	117	117
Maximum boiler temperature setting	[°C]	90	90	90
Permitted operating pressure	[bar]	4	4	4
Permitted fuel as per EN ISO 17225 ¹⁾		Part 2: Wood pellets class A1 / D06 Part 4: Wood chips class A2 / P16S-P31S		

		35	45	50
Nominal output	[kW]	35	45	49,9
Thermal output range	[kW]	10,5 - 35	13,5 - 45	14,9 - 49,9
Electrical connection	[V/Hz/A]	400V / 50Hz / fused C16A		
Power consumption wood chip mode NL/PL	[W]	63 / 38	85 / 61	94 / 61
Power consumption pellet mode NL/PL	[W]	84 / 46	96 / 49	97 / 49
Weight of boiler (including stoker, without water)	[kg]	740	850	850
Boiler capacity (water)	[l]	117	155	155
Maximum boiler temperature setting	[°C]	90	90	90
Permitted operating pressure	[bar]	4	4	4
Permitted fuel as per EN ISO 17225 ¹⁾		Part 2: Wood pellets class A1 / D06 Part 4: Wood chips class A2 / P16S-P31S		

		60	80	90
Nominal output	[kW]	60	80	90
Thermal output range	[kW]	18 - 60	24 - 80	27 - 90
Electrical connection	[V/Hz/A]	400V / 50Hz / fused C16A		
Power consumption wood chip mode NL/PL	[W]	113 / 61	114 / 47	126 / 51
Power consumption pellet mode NL/PL	[W]	99 / 49	102 / 48	116 / 49
Weight of boiler (including stoker, without water)	[kg]	850	1160	1160
Boiler capacity (water)	[l]	155	228	228
Maximum boiler temperature setting	[°C]	90	90	90
Permitted operating pressure	[bar]	4	4	4
Permitted fuel as per EN ISO 17225 ¹⁾		Part 2: Wood pellets class A1 / D06 Part 4: Wood chips class A2 / P16S-P31S		

		100	110	130
Nominal output	[kW]	100	110	130
Thermal output range	[kW]	30 - 100	33 - 110	39 - 130
Electrical connection	[V/Hz/A]	400V / 50Hz / fused C16A		
Power consumption wood chip mode NL/PL	[W]	138 / 56	138 / 57	136 / 59
Power consumption pellet mode NL/PL	[W]	129 / 48	128 / 49	124 / 52
Weight of boiler (including stoker, without water)	[kg]	1160	1160	1500
Boiler capacity (water)	[l]	228	228	320
Maximum boiler temperature setting	[°C]	90	90	90
Permitted operating pressure	[bar]	4	4	4
Permitted fuel as per EN ISO 17225 ¹⁾		Part 2: Wood pellets class A1 / D06 Part 4: Wood chips class A2 / P16S-P31S		

T4e WOOD CHIP BOILER

		140	150	160
Nominal output	[kW]	140	150	160
Thermal output range	[kW]	42 - 140	45 - 150	48 - 160
Electrical connection	[V/Hz/A]	400V / 50Hz / fused C16A		
Power consumption wood chip mode NL/PL	[W]	137 / 58	136 / 59	136 / 60
Power consumption pellet mode NL/PL	[W]	125 / 51	124 / 52	124 / 52
Weight of boiler (including stoker, without water)	[kg]	1500	1500	1500
Boiler capacity (water)	[l]	320	320	320
Maximum boiler temperature setting	[°C]	90	90	90
Permitted operating pressure	[bar]	4	4	4
Permitted fuel as per EN ISO 17225 ¹⁾		Part 2: Wood pellets class A1 / D06 Part 4: Wood chips class A2 / P16S-P31S		

		170	180	200
Nominal output	[kW]	170	180	199
Thermal output range	[kW]	51 - 170	59 - 180	59 - 199
Electrical connection	[V/Hz/A]	400V / 50Hz / fused C16A		fused C25A
Power consumption wood chip mode NL/PL	[W]	136 / 60	136 / 61	135 / 62
Power consumption pellet mode NL/PL	[W]	123 / 53	122 / 54	120 / 55
Weight of boiler (including stoker, without water)	[kg]	1500	1500	2500
Boiler capacity (water)	[l]	320	320	438
Maximum boiler temperature setting	[°C]	90	90	90
Permitted operating pressure	[bar]	4	4	4
Permitted fuel as per EN ISO 17225 ¹⁾		Part 2: Wood pellets class A1 / D06 Part 4: Wood chips class A2 / P16S-P31S		

		250	300	350
Nominal output	[kW]	250	350	350
Thermal output range	[kW]	75 - 250	90 - 300	105 - 350
Electrical connection	[V/Hz/A]	400V / 50Hz / fused C25A		
Power consumption wood chip mode NL/PL	[W]	214 / 62		
Power consumption pellet mode NL/PL	[W]	162 / 55		
Weight of boiler (including stoker, without water)	[kg]	2500	3175	3175
Boiler capacity (water)	[l]	438	783	783
Maximum boiler temperature setting	[°C]	90	90	90
Permitted operating pressure	[bar]	4	4	4
Permitted fuel as per EN ISO 17225 ¹⁾		Part 2: Wood pellets class A1 / D06 Part 4: Wood chips class A2 / P16S-P31S		

¹⁾Detailed information on the fuel is included in the operating instructions, in the section on "Permitted fuels"

The ecodesign requirements according to VO (EU) 2015/1189, Annex II, point 1. are met.

OPERATING AND

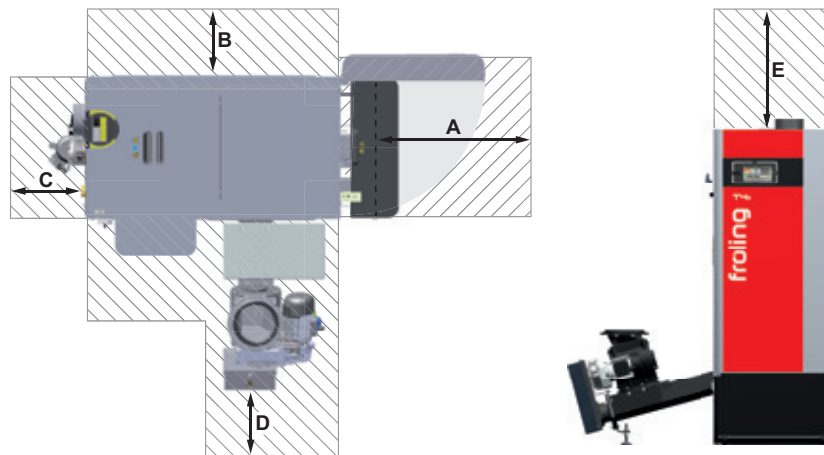

Minimum clearances [mm]	20	25	30	35	45
A Insulated door to wall	700	700	700	700	700
B Side of boiler to wall	150	150	150	150	150
C Back of boiler to wall	500	500	500	500	500
D Stoker to wall	300	300	300	300	300
E Maintenance area above the boiler	500	500	500	500	500
Minimum room height	1800	1800	1800	1800	2000

	50	60	80	90	100
A Insulated door to wall	700	700	800	800	700
B Side of boiler to wall	150	150	150	150	150
C Back of boiler to wall	500	500	500	500	500
D Stoker to wall	300	300	300	300	300
E Maintenance area above the boiler	500	500	500	500	500
Minimum room height	2000	2000	2100	2100	2100

	110	130	140	150	160
A Insulated door to wall	800	800	800	800	800
B Side of boiler to wall	150	150	150	150	150
C Back of boiler to wall	500	500	500	500	500
D Stoker to wall	300	300	300	300	300
E Maintenance area above the boiler	500	500	500	500	500
Minimum room height	2100	2350	2350	2350	2350

	170	180
A Insulated door to wall	800	800
B Side of boiler to wall	150	150
C Back of boiler to wall	500	500
D Stoker to wall	300	300
E Maintenance area above the boiler	500	500
Minimum room height	2350	2350



Pellet boiler

PE1 Pellet	7 - 35 kW	P4 Pellet	48 - 105 kW
PE1c Pellet	16 - 22 kW	PT4e	120 - 250 kW
PE1e Pellet	45 - 60 kW		



Firewood boiler

S1 Turbo	15 - 20 kW
S3 Turbo	20 - 45 kW
S4 Turbo	22 - 60 kW

Dual fuel boiler

SP Dual compact	15 - 20 kW
SP Dual	22 - 40 kW



Wood chip boiler / large systems

T4e	20 - 350 kW	TI	350 kW
Turbomat	150 - 550 kW	Lambdamat	750 - 1500 kW

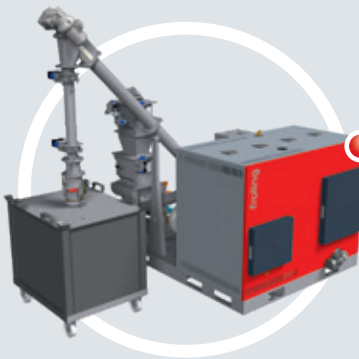

Heat and electricity from wood

Fixed bed gasifier CHP	46 - 56 kW (power consumption)
	95 - 115 kW (thermal output)

Your Fröling partner

Fröling Heizkessel- und Behälterbau Ges.m.b.H.
A-4710 Grieskirchen, Industriestr. 12

AT: Tel +43 (0) 7248 606-0
Fax +43 (0) 7248 606-600

DE: Tel +49 (0) 89 927 926-0
Fax +49 (0) 89 927 926-219

E-mail: info@froeling.com
Web: www.froeling.com